

AGRICULTURAL MACHINERY

sitrex®
Spa

**ASSEMBLY,
USE AND MAINTENANCE
SPARE PARTS LIST**

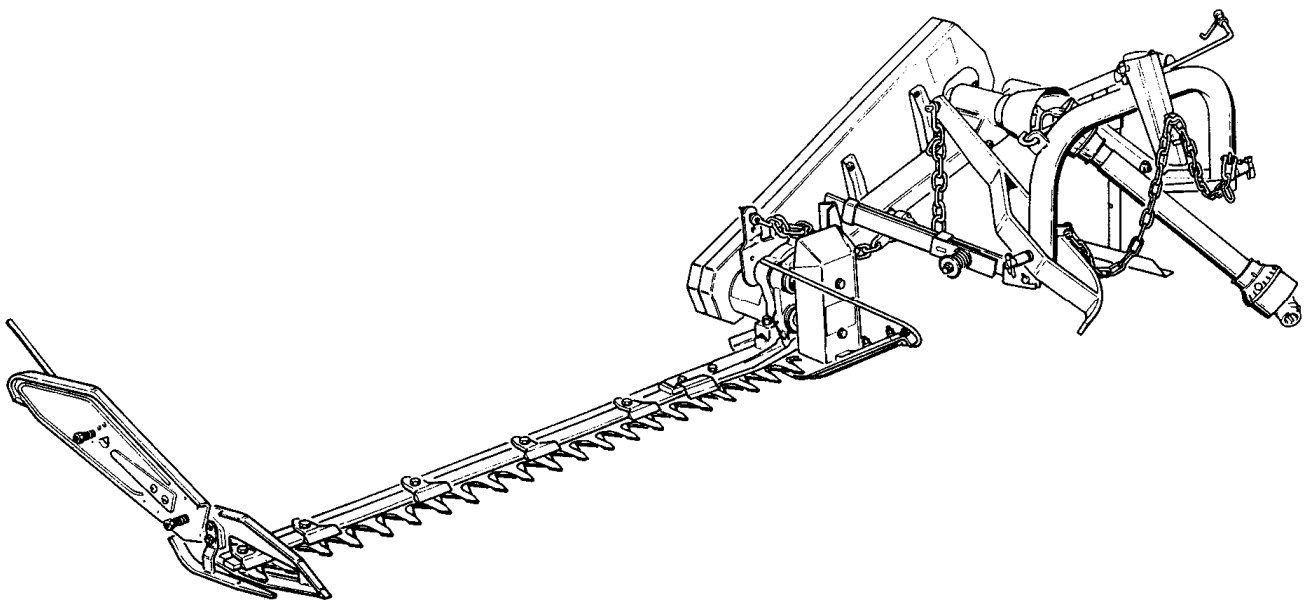

SB/150 - SB/165
SB/180 - SB/210

DEAR CUSTOMER,

WE WOULD LIKE TO WELCOME YOU AS OUR-PRODUCT USER AND THANK YOU FOR CHOOSING OUR MACHINE.

OUR MACHINES ARE THE RESULT OF CAREFUL STUDY AND YEARS OF EXPERIENCE. WE HAVE ALWAYS PLACED IMPROVEMENT AMONG OUR PRIME OBJECTIVES.

WE WOULD LIKE TO POINT OUT, HOWEVER, THAT FOR LASTING PROTECTION OF THE CAPITAL YOU HAVE INVESTED, IT IS NECESSARY TO FOLLOW THE INSTRUCTIONS IN THIS BOOKLET WHICH ILLUSTRATES THE CHARACTERISTICS, THE OPERATION AND THE MAINTENANCE OF THE MACHINE IN DETAIL.

THE CONTENTS OF THIS BOOKLET ARE INTENDED TO BE A GUIDE, **THE MANUFACTURER** RESERVES THE RIGHT TO MODIFY THE SPECIFICATIONS OF THE MACHINE WITHOUT BEING OBLIGED TO IMMEDIATELY UP-DATE THIS BOOKLET.

WARNING

BEFORE STARTING THE MOWING OPERATIONS ALWAYS CHECK THAT ALL THE CONNECTIONS ARE THOROUGHLY TIGHTENED.

THE MOWER MUST NEVER BE OPERATED WHILE ANYONE IS WITHIN RANGE OF THE MACHINE.

THE MANUFACTURER DECLINE EVERY RESPONSIBILITY FOR EVENTUAL ACCIDENTS SHOULD HAPPENED AFTER A WRONG OR BAD USE OF THE MACHINE.

SAFETY INFORMATION & WARNING



WARNING !!!



Always read your operators manual thoroughly before operating or performing any maintenance on your mower. Before you operate this machine, know your controls and how to stop the tractor and mower quickly in an emergency! Read and observe all safety decals on the tractor and mower.

Use extreme caution and reduce speed when operating on hillside. Use cabs equipped with ROPS (Roll Over Protection) and seat belts. Mowers are more likely to throw objects when operating on hillside and tractors can easily tip. Either could result in serious injury to operator. Never start or stop suddenly when going up or downhill. This could result in tipping of the tractor or a roll-over. If steep slopes are anticipated, adjust the wheel width, add fluid to tires or add tractor weights to compensate. Avoid steep slopes. Do not raise the cutter bar when mowing hillsides. Doing so may increase the likelihood of tipping.

Only the operator should ride on the tractor no one should ride on the mower. Persons riding on the tractor or the mower could easily fall into the path of the machine resulting in serious injury. Anyone operating this machine must be instructed in the operation and capable of safe operation of the unit. Never allow children to operate this machine!

Never use drugs or alcoholic beverages which can hinder alertness or coordination while operating. Consult your doctor about operating this machine while taking prescription drugs.

Always keep all covers, blades and guards, furnished with the machine, in place and in good condition. Failure to do so could result in the operator being struck by high speed cutter bar. Keep clear all mowing parts.

Make sure all onlookers personnel, children and pets are out of the area to be mowed. Make sure pets and small children are not under or around the machine when you start the mower.

Always wear proper foot protection. Never operate the mower in bare feet or while wearing sandals or sneakers.

Always operate in daylight conditions or use sufficient artificial lighting. Use extreme caution when mowing under conditions which could hinder your ability to see people, pets or obstructions in the mowing area.

Always check the drive line connections at the tractor and the gearbox before operation of the mower. Be sure the quick disconnects are locked before operation.

Always disengage the tractor PTO and shift into neutral before starting the tractor.

Always lower the mower to the ground and shut off the tractor before dismounting and be sure that the mowing motion has stopped

Failure to do so could result in the operator being injured by mowing tractor, mower or driveline parts.

Always stop the tractor's engine and disengage the PTO before making adjustments or cleaning the mower.

Always disengage the driveline and block up the machine before performing maintenance on the mower.

Never operate the mower while in the raised of the transport position.

Avoid sharp turns while mowing. Remember that a 3-point mounted mower will swing in a wide arc when the tractor is turned. Allow sufficient clearance for the mower when turning.

Always stop the mower and tractor upon hitting an obstruction. Stop the tractor engine and inspect the mower before resuming operation.

Observe minimum and maximum PTO RPM limits. Failure to do so could result in damage to equipment. Use only 540 RPM.

When transporting the mower on public roads, always use the tractor's safety warning lights and slow mowing vehicle emblem. Consult local regulations about the use of additional lights or flashers.

Perform preventive maintenance on a regular basis. Replace worn or damaged parts immediately. Keep all nuts and bolts tight at all times. Failure to do so could result in serious injury to personnel or machinery. Make sure all safety decals are in place and visible. Replace decals immediately when they become illegible.

Do not use this machine in extremely rocky field conditions.

Never operate the mower with cutter bar locked in the UP position or any time the cutter bar locked in the UP position or any time the cutter bar is raised. Never allow anyone near the cutter bar when the tractor is running.

Always lock the cutter bar in the UP position for transport, whenever the cutter bar is in the UP position with no hydraulic pressure on the cutter bar cylinder or whenever the cylinder is removed. Failure to lock the cutter bar in this position could result in the cutter bar falling to the ground and causing injury.

Never allow children to operate on ride on the tractor or cutter:

Children 16 years old or older who are large enough to reach the controls safely, who are welltrained and supervised, and who have read the operations manual and understand the potential hazards are usually capable of operating the mower in a reasonable manner.

This mower is of metric design. USE ONLY METRIC TOOLS. Other wrenches may slip and cause bodily injury and may ruin the fastener and require costly replacement.

**CAUTION**

Never disconnect mower from tractor without cutter bar in the lowered (operating) position.

IMPORTANT

The following Safety and Informational Decals are located on the **SICKLE-BAR MOWING**.

Locate , read and understand these Decals.

Replace any damaged Decals. Keep all Decals clear and readable.

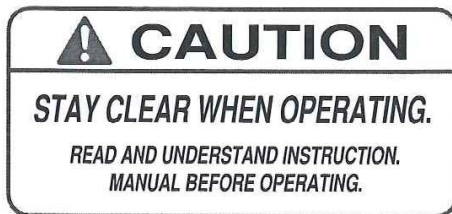

TECHNICAL CHARACTERISTICS

WORKING WIDTH	ft	5' - 6' - 7'
THEORETIC POWER	hp	12/16
MOUVEMENT FREQUENCY MINUTE	N°	1250/1300
WORKING SPEED	mph	6/8
REQUIRED REVS P/T	rpm	500/550
YIELD OUT PUT PER HOUR	acre	3,5-5
SAFETY DEVICES		release
POSSIBILITY OF WORKING WITH INCLINED BAR		+90°-60°
HYDRAULIC LIFT		optional
DRIVE		"V" belt
INDICATIVE WEIGHT	lb	520 - 550

ASSEMBLY INSTRUCTIONS

1. CAUTION



Attach lifting lever 5 to arch frame 9 inserting pin 4 and inserting bushing 3 on the other side, and

fasten with washer 2 and nut 1. For a safer and simpler assembly, it is recommended that the three-point arch frame be attached to the tractor or to another similar support.

Use bushings 8 and 10 to adapt the pins to different types of tractor attachments.

Position lever 11 and bushing 10 (if needed) and secure with pin 13 and pin 14.

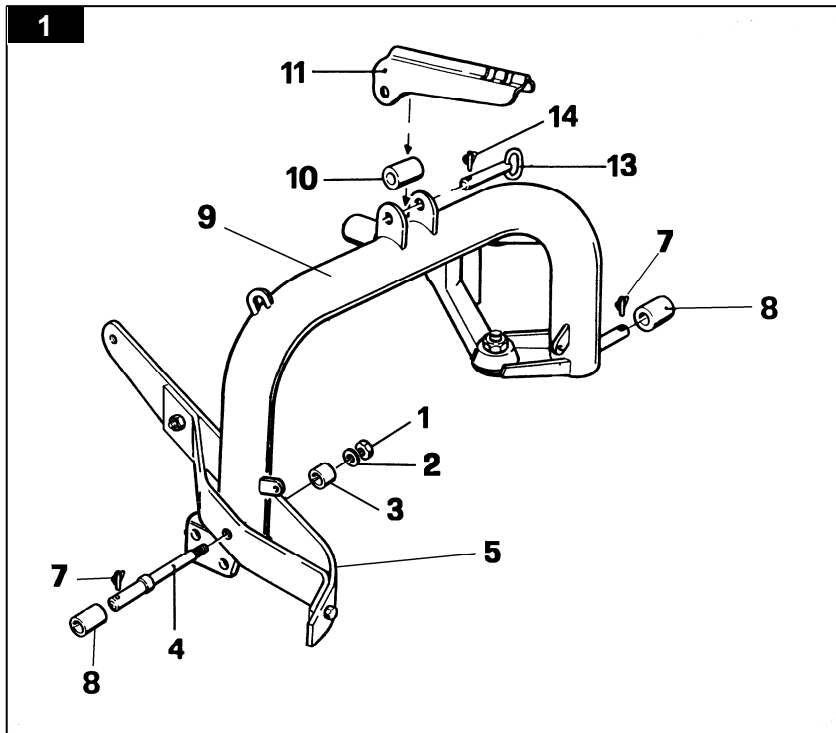

2. CAUTION



Attach safety bar 2 at the hole indicated on arch frame 1 with pin 3 and secure pin 3 with pins 4.

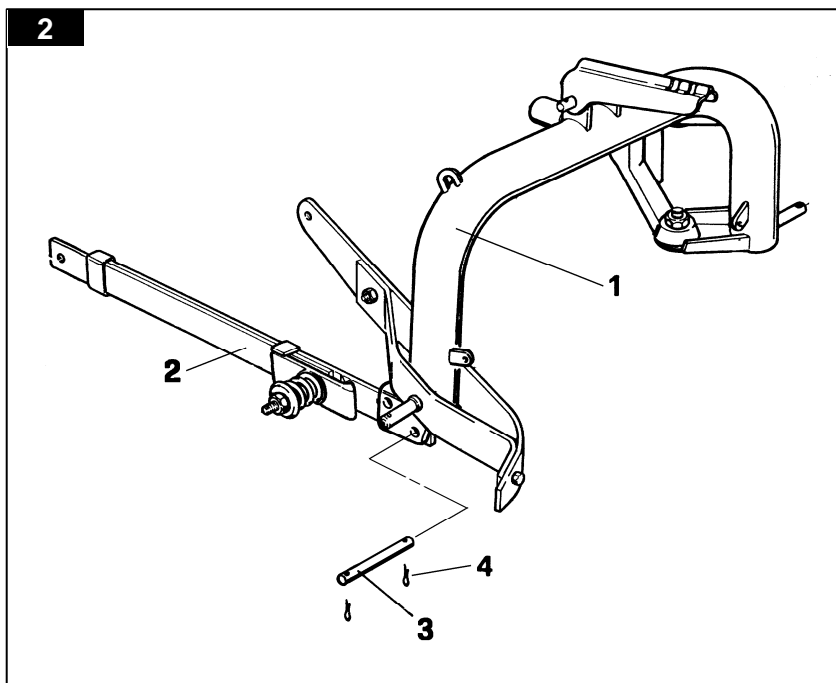

3. DANGER



Remove paint from the part of pin 1 that must enter in bushing 3 of the belt drive assembly to make insertion easier. Load spring 2 securing the longer end in place at point C (drive assembly)

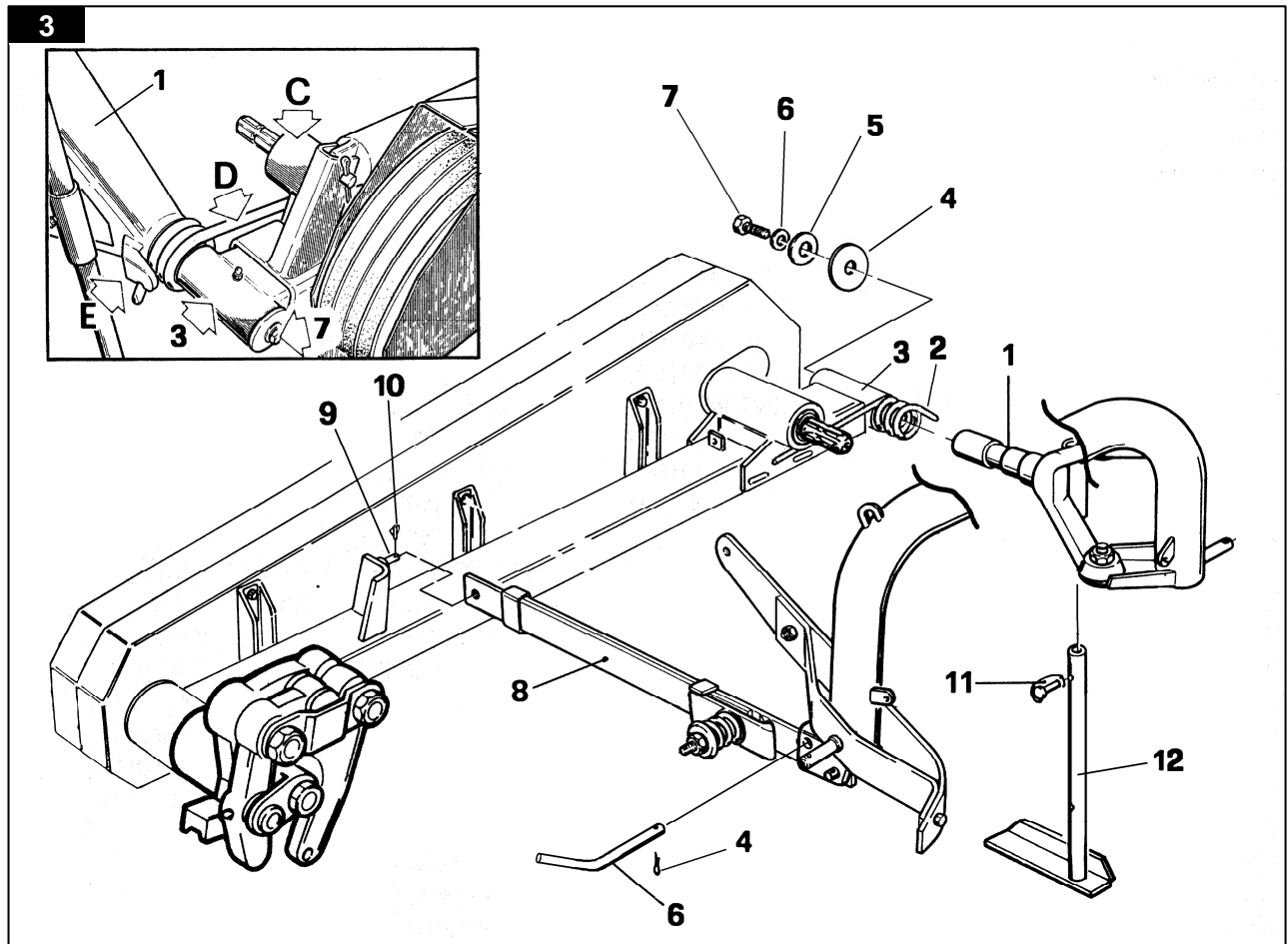

and the shorter end at point E of support 1 as indicated in the detail in the illustration. Fasten pin 1 with washers 4, 5 and 6 and screw 7. With the spring under tension join safety bar 8 to pin 9 on the drive assembly and secure with pin 10. Insert pin 6 and secure with pin 4.

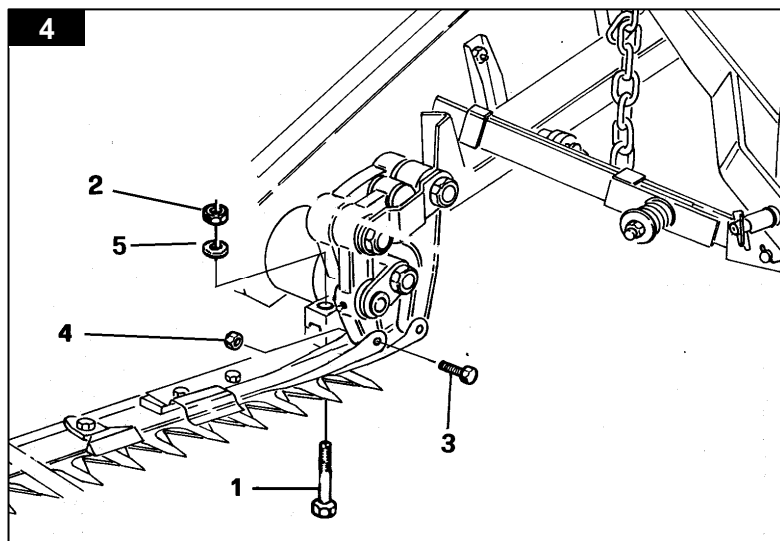

4. ATTENTION



Mount the blade assembly to the drive assembly using screws 1, washers 5 and nuts 2, and fasten blades with screws 3 and nuts 4.

5. CAUTION



Attach plate 9 to frame 7 using screws 14 and spring 8 and tighten nut 6 and washers 5 without completely compressing spring 8 (pieces 14, 8, 12 and 6 are contained in the nuts & bolts sack). Attach rod 10 in the same manner, without compressing spring 12, with nut 16 and washer 15.

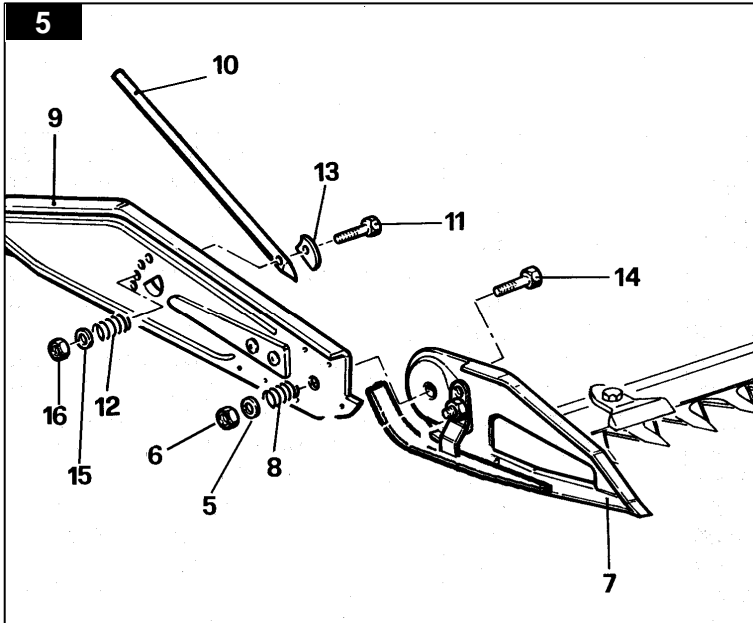

6. CAUTION



Attach bracket 1 to the drive assembly 6 inserting also screws 13 of shoe 7 (packed preassembled) and positioning screws 5, tightening all with washers 9 and 10 and nuts 8. Attach safety guard 2 to bracket 1 using nuts 3 and washers 4.

Connect the chains of connecting rod 15 to fasteners 17 and 16, which are bigger than the fasteners to be used for the chain in Fig. 8, Ref. G. Attach rod 14 to shoe 7 using nut 11 and washer 12.

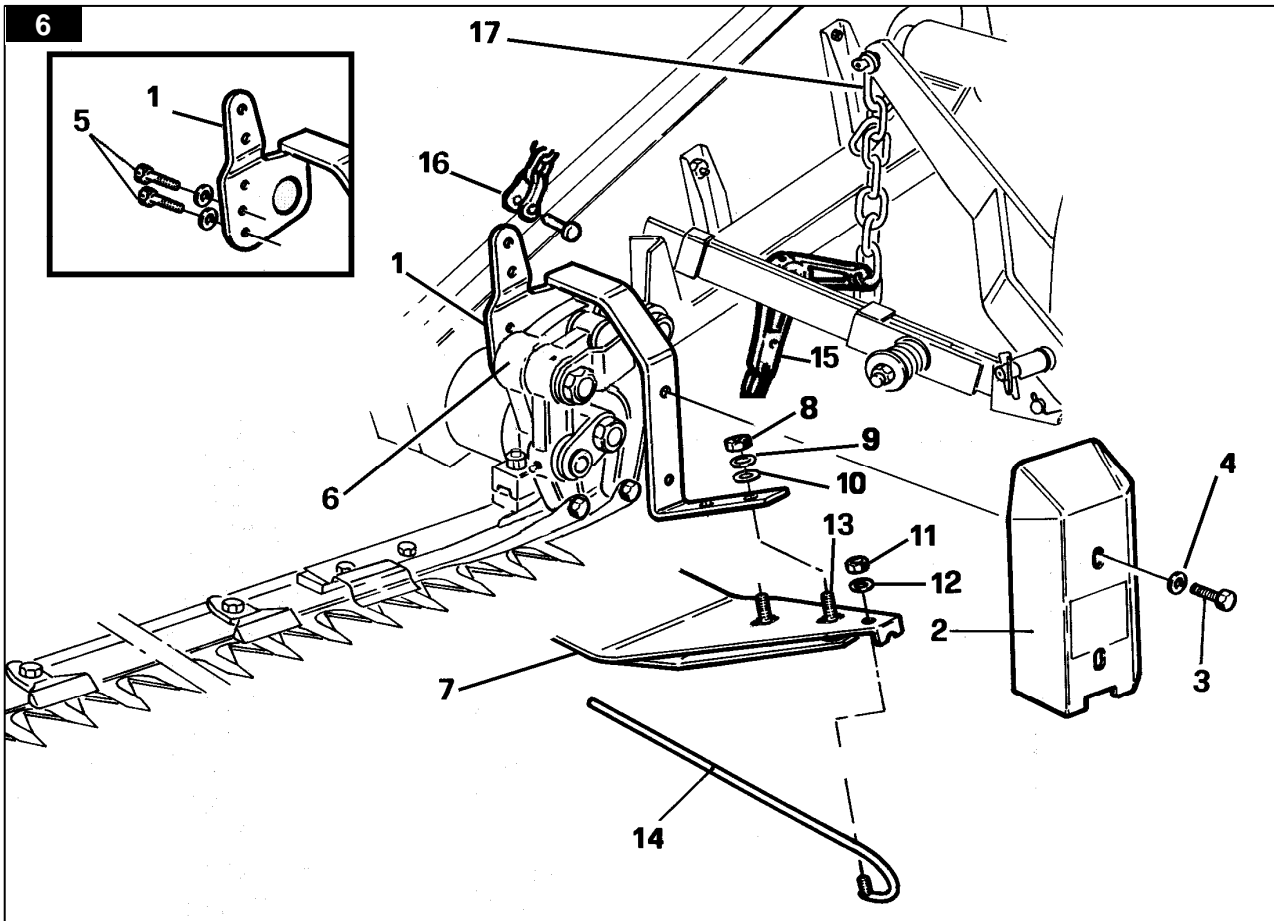

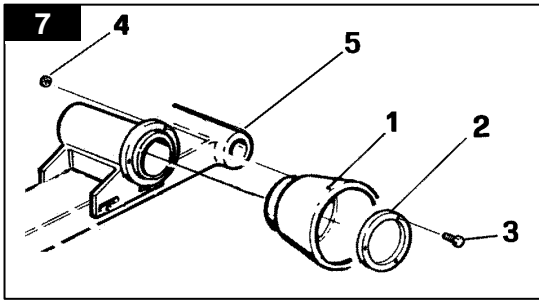

7.

Connect the protective casing 1 to the power take-off support 5 using ring 2, screws 3 and nuts 4 contained in the nuts & bolts sack.

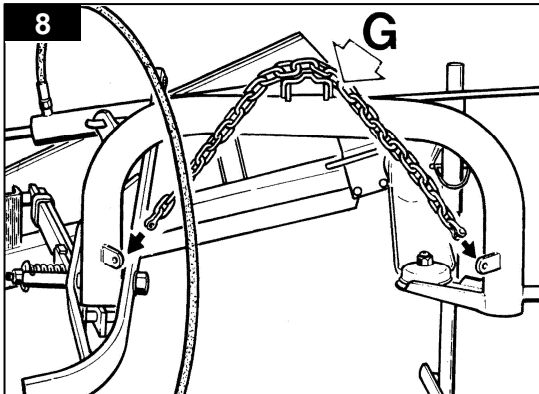

8.

Connect the chain (Rif.G) to the frame making use of the appropriate fasteners. (see also Fig.9 Ref.5).

9.

Slide the transport rod 1 into slot 4 on the three-point arch frame and fit it into hook 3. Screw the bar locking handle 2 (contained in the nuts & bolts sack) onto rod 1.

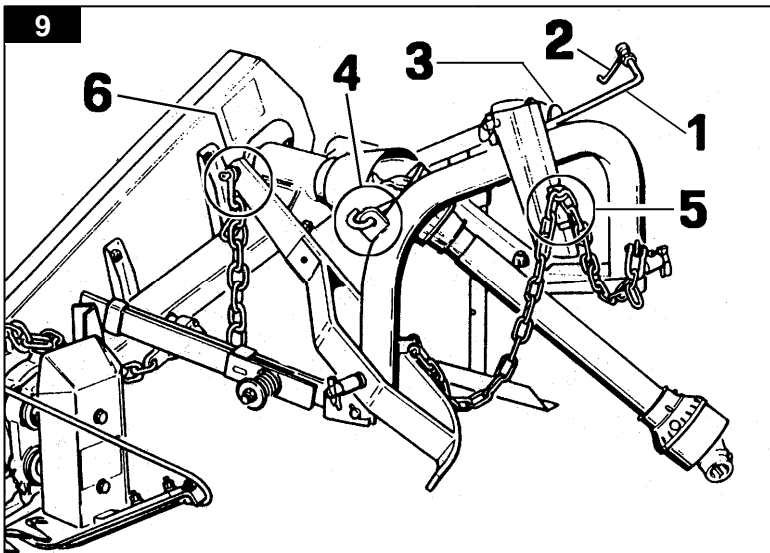

When assembly is completed, the machine should look as it appears in the illustration.

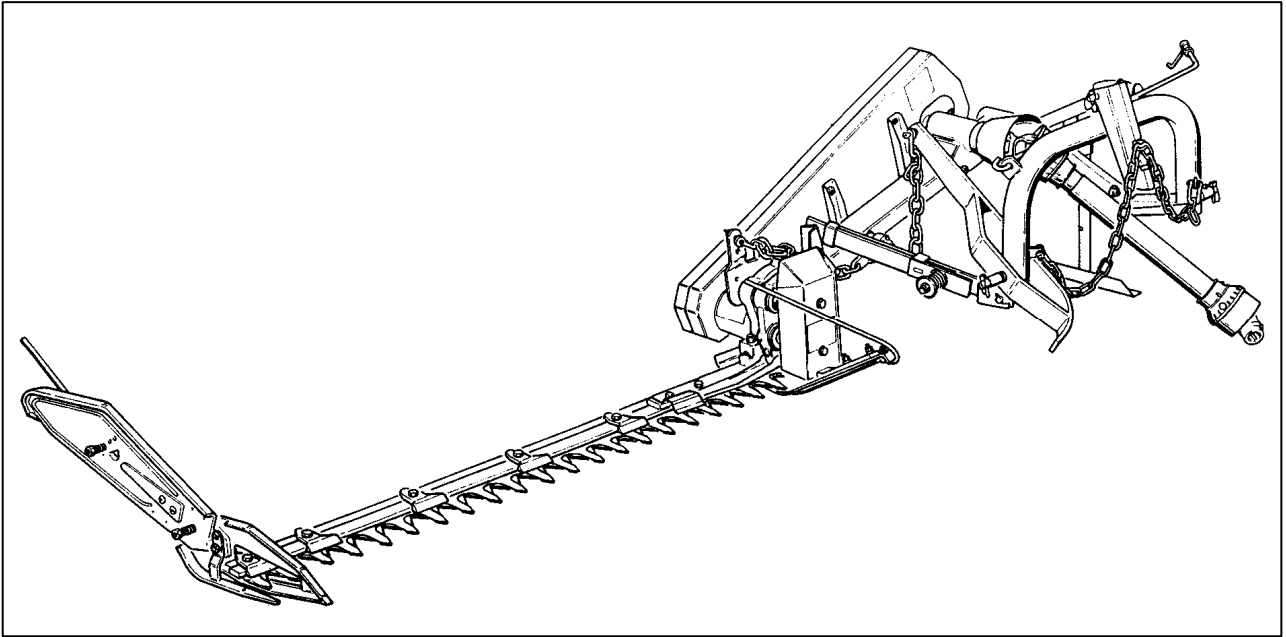

STARTING UP and USE

FRAME

Connect the Mower to the three-point attachment of the tractor inserting the gear rack in the pin of the third point, rest the chain "D" against it and connect the ends to the frame with the relative clamps. Regulate the stabilizing tie-rods so that the machine is well cantered. Block the support in the working position and extract the stop pin of the frame.

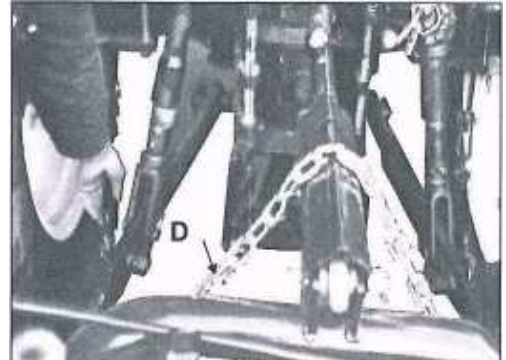

CONNECTING THE CARDAN SHAFT



It is your responsibility to read and comply with this documentation. If information given in this manual should conflict with that given in the Cardan shaft manual, you should follow the instructions given by the Cardan shaft manufacturer.

Fit the Cardan shaft and check that the shaft is connected correctly both at the tractor end and at the machine end. For more details, see the descriptions on the following pages. If a safety system is provided, this should be fitted to the machine end, not to the tractor end.

During both transport and use, avoid conditions where the Cardan transmission shaft is extended to the maximum. In all working conditions, the telescopic tubes must overlap by at least 1/3 of their length.

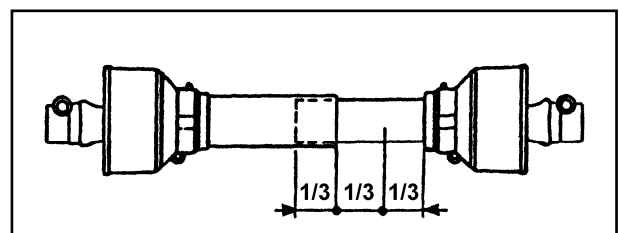

Conversely, when the Cardan shaft is contracted to the maximum, there should still be a gap of approximately 50 mm (2").

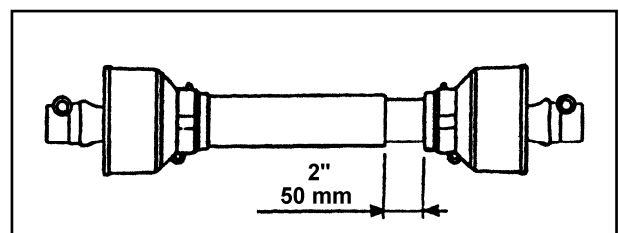

LIFTING

Adjust the chains of the mower rocker arm so that when operating the lifting device the bar rises creating an upwards angle of about $15/20^\circ$, then manually bring it to a vertical position and secure it to the bar stop tie rod by means of the relative winder nut.



DANGER !!!



Never transporting the mower without secure it through the tie rod.

WORKING POSITION

- 1) Clear the tie-rod bar and lower it manually supporting it at the end-of-stroke. Lock the bar stop tie-rod in the relative slot.
- 2) The chain of the third point serves to block the frame at a certain height. Lower the tractor hoist and regulate the chain length on the gear rack so as to obtain the right pressure of the spring and a good alignment of the driveline with the power take-off "D".

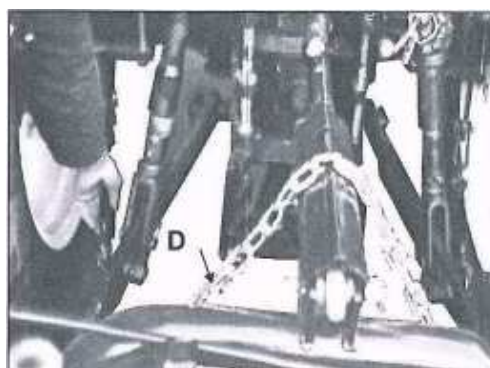

CUTTING HEIGHT

The cutting height is regulated by means of the third point of the tractor, which permits the downwards inclination of the front part of the bar.

However we recommend that you do not mow too near the ground when it is very stoney in order to avoid the risk of damaging the blades.

SAFETY RELEASE

The mower is fitted with a safety release that allows the bar to rotate backwards in the event of impact. It is not possible to provide an optimal calibration at origin due to the diversity of terrain, it is therefore advisable to regulate the spring pressure using the relative nut "A"

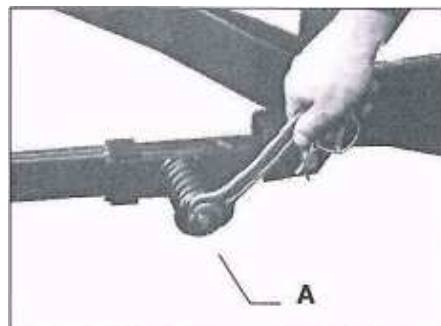

BELT TENSION

It is important to check the belt tension especially in the first hours of working. To check the tension, it is necessary to exert upon each belt a pressure of nearly lb. 8/9 if the flexion is over 1/2" "A", proceed as follows:

- 1) Lift the machine so as to unload the spring.
- 2) Loosen the two M14 bolts of the pulley support "C".
- 3) Stretch the belt by means of the relative M14 screw after having loosened the lock-nut "B".
- 4) Check that the tension is correct and then tighten the M14 bolts.

When the belts are worn always replace them in complete series (3 belts).

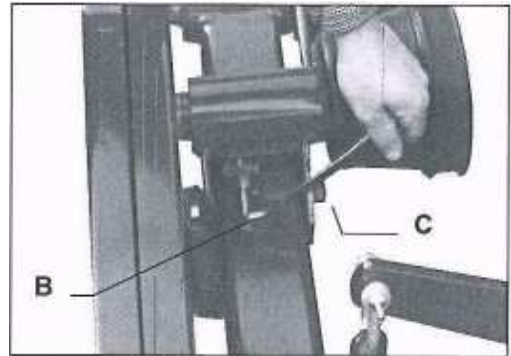
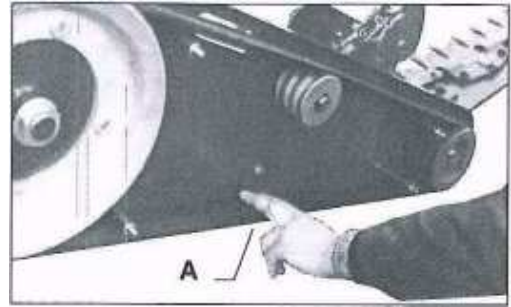

USE

To begin mowing work, after having placed the bar on the ground, the blades should be well oiled and the relative parts greased, then insert the power take-off and accelerate gradually until reaching a speed of 500-550 revs per min.

BLADE REPLACEMENT

Blade replacement in the mowers is greatly facilitated by the new fixture system and is carried out as follows: unscrew the three M8 screws "D" rotate the head upwards (this remains attached to the connect rod kit), and extract the blade from the exterior using the relative hook. To re-assemble the blade make sure that the alignment of the two pegs with the head is perfect (clean if necessary), then tighten the three screws. The toothed blade is extracted from the interior by unscrewing the M12 bolt that locks the head to the connect rod kit lever "E".

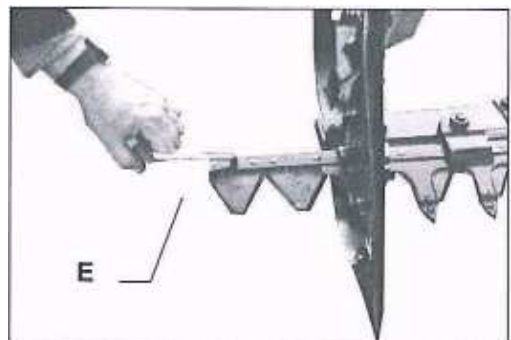
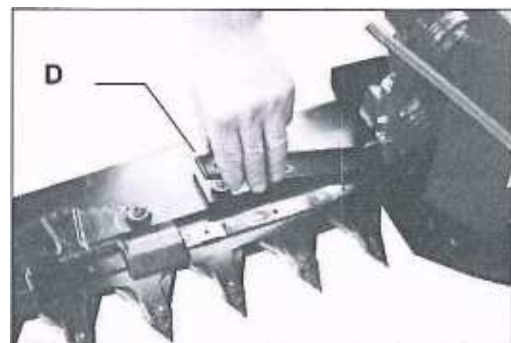

MOWING WITH INCLINED BLADE

Mowing is possible with the any type of blade inclination, either upwards or downwards (+90°-60°), for cutting bushes, embankments, ditches, etc. To allow the bar to rotate downwards, release the chain from the bracket and fit an extension to the cylinder (if supplied).

BLADE HOLDER REGISTRATION

It is possible that in time the registration of the blade holder will be necessary. This is undertaken as follows:

- 1) Loosen the two M12 nuts "A" wrench.
- 2) Adjust the relative M10 screw "B" leaving a clearance of 0.3-0.5 mm between the blade holder and the tooth.
- 3) Tighten the two M12 nuts "A" and check the clearance with a thickness gauge.

We however advise that this operation is carried out by authorized dealers.

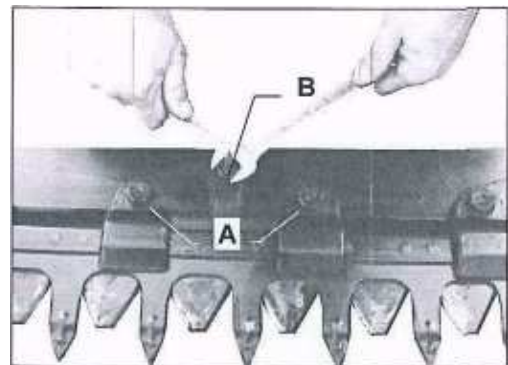

MOWER TRANSPORTATION AND STORAGE

Lift the tractor hoist and put the bar into vertical position and secure it to the tie-rod "D". The mower is ready for transportation.

For storage, lower the support and insert the pin so as to block the frame "C", lower the hoist and unhook the machine from the tractor. It is advisable to wash the mower at the end of the mowing operation and grease the bar before storing it away for the winter, it is also advisable to position it with the bar horizontal to avoid the risk of accidental overturning and belt loosening.

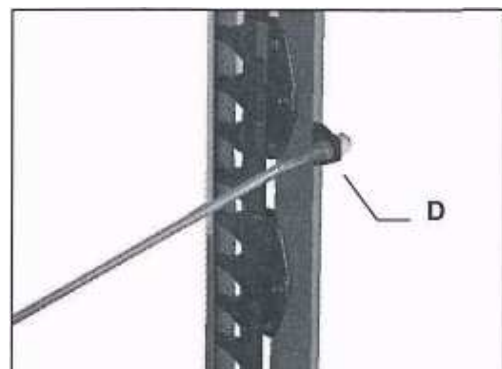

HYDRAULIC SYSTEM (OPTIONAL)

All the mowers can be provided with an hydraulic lifting device. This accessory could only be purchased by direct request. It use exclusively to lift the cutter-bar in a vertical position for transporting. Operate by means of a single acting cylinder.

ASSEMBLY

Insert the support in the arm and fix it through the two bolts M12 "A". Than secure the cylinder end point with the apposite piston pin "F".

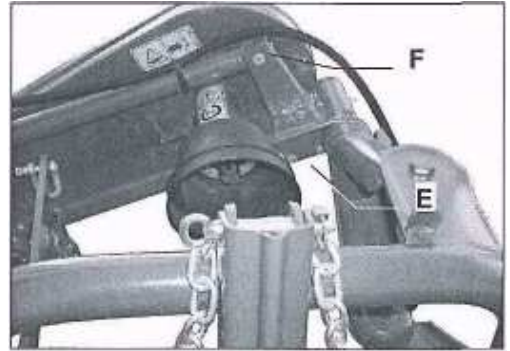

Assemble the second support with unit through the two bolts M12 "A" to insert the piston rod in the pin and to secure it through the apposite pin.

Connect the flexible tube end-point to the cylinder "B" and connect the other end-point the hydraulic device of the tractor.

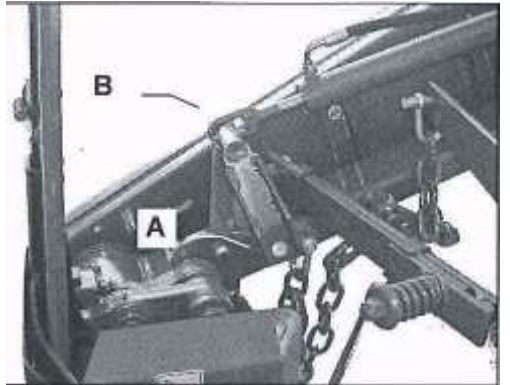

USE

- 1) To stop the power take-off of the tractor.
- 2) To lift the mower through the lifting device of the tractor.
- 3) To operate the cylinder for the total lifting of the bar.

LUBRIFICATION

The mower are delivered already lubricated.

Grease all parts at least every 8 working hours, especially the central (Rif. M). In order to avoid excessive wear it is indispensable to wash the bar with water at the end of any mowing.

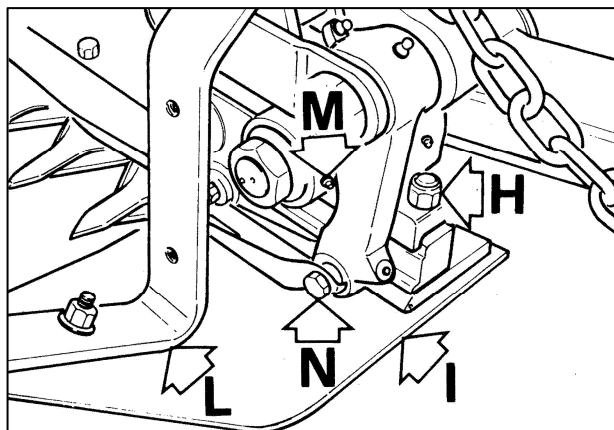

DRIVELINE

Grease Fitting are located on the Cross Assembly of each U Joint and on the Telescoping Tubes. Do not force grease through the Needle Cup Assemblies.

Use quality grease to lubricate each part after the number of hours shown in the chart. Consult the shaft operation and maintenance manual.

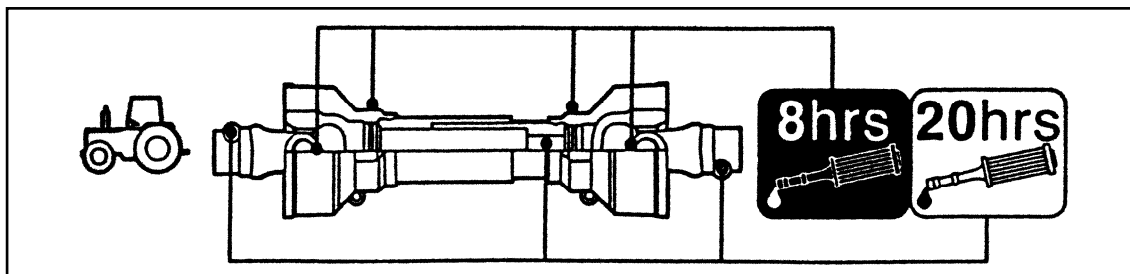

TROUBLE	CAUSE	REMEDY
NOT CUTTING CLEAN	<ol style="list-style-type: none"> 1. Blades dull. 2. RPM too slow. 3. Ground speed too fast. 	Sharpen or replace. Use correct rotation. Reduce ground speed.
STREAKING	<ol style="list-style-type: none"> 1. Crop too wet. 2. Dull blades. 3. Mud or debris built up between skid shoes. 	<p>Allow crop to dry. Slow ground speed.</p> <p>Sharpen or replace blades.</p> <p>Clean area between skids.</p>
STUBBLE TOO LONG	<ol style="list-style-type: none"> 1. Angle on cutter bar incorrect. 2. Insufficient down pressure on cutterbar. 	<p>Change angle using the top link.</p> <p>Adjust spring tension.</p>
SOIL BUILD UP ON CUTTERBAR	<ol style="list-style-type: none"> 1. Wet conditions 2. Too much cutterbar down pressure. 	<p>Allow to dry.</p> <p>Adjustn spring tension</p>
MOWER BREAKS BACK TOO EASILY	<ol style="list-style-type: none"> 1. Insufficient tension on break away spring. 	Tighten breakaway spring

SPARE PARTS LIST

SB/150 - SB/165

SB/180 - SB/210

LAYOUT OF THE TABLES

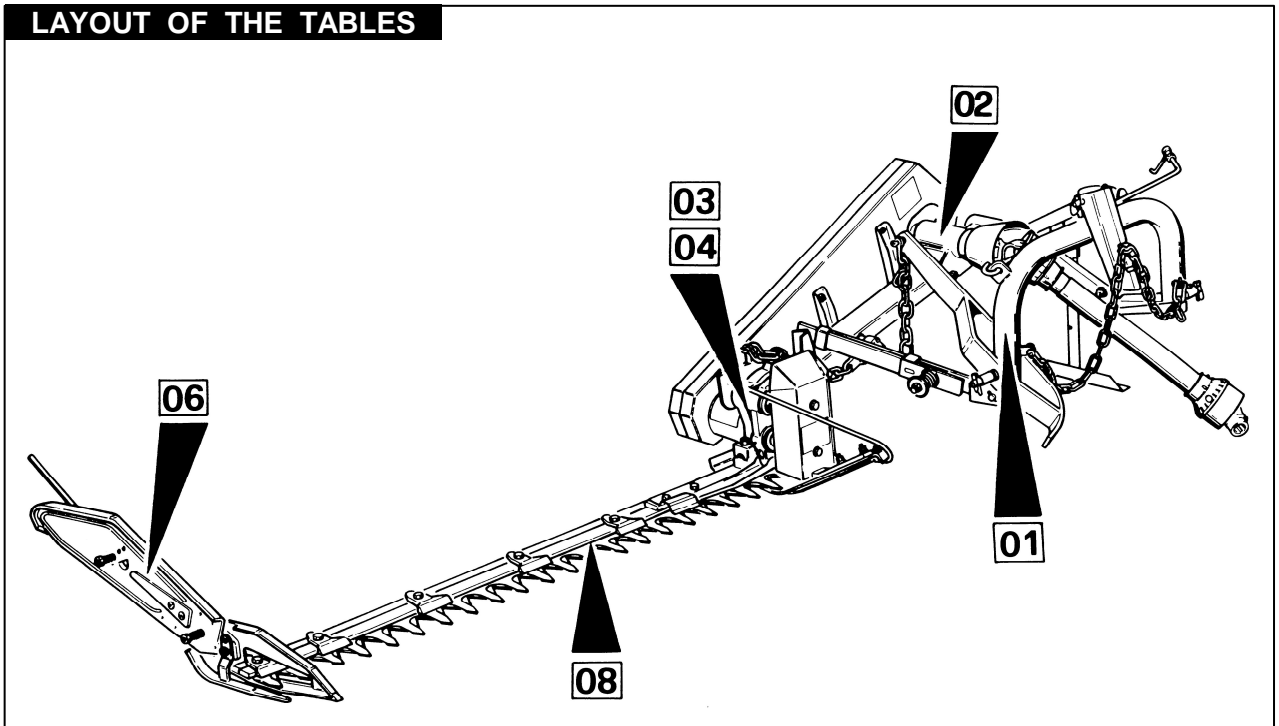

TAB. 01 SB			
ITEM	PART.NO	DESCRIPTION	NOTE
1	100.368	FRAME	
2	100.369	SUPPORT	
3	610.605	BOLT, COMPLETE	
4	100.370	SPACER	
5	100.371	GEAR RACK	
6	100.372	CHAIN, COMPLETE	
7	100.373	PIN	
8	610.606	PIN	
9	600.244	NUT M24x2 DIN 934 CLASS 8	
10	100.374	REDUCER INSERT	
11	100.375	SPACER	
12	100.376	LEVER	
13	100.377	PIN	
14	100.378	PIN	
15	100.379	REDUCER INSERT	
16	610.608	BOLT, COMPLETE	
17	100.380	WASHER	
18	600.842	PIN	
19	100.382	SUPPORT	
20	100.383	TIE ROD	
21	100.518	HANDLE	
22	100.384	SPRING	
23	100.385	ICE SLED	
24	100.387	SPRING	
25	100.388	WASHER	
26	100.389	PLATE	
27	600.197	NUT M16 DIN 982 CLASS 6	
28	100.390	ICE SLED	
29	100.392	FRAME	
30	600.246	WASHER D. 25 UNI 1751A	
31	610.685	SPECIAL NUT	
32	610.684	SCREW M18x1.5x65 DIN 960 CLASS 8.8	
33	610.687	THIMBLE 3/8"	
34	100.516	CHAIN	
35	600.038	SPLIT PIN 6x35 DIN 94	
36	600.616	SCREW M12x35 DIN 933 CLASS 8.8 ZN	
37	600.018	WASHER D. 13 UNI 1751A	
38	600.089	WASHER D. 13 DIN 125A	
39	600.015	PIN	
40	100.517	PIN	
41	600.084	NUT M16 UNI 5587 CLASS 8	
42	100.526	LEVER	
43	100.527	SUPPORT	
44	600.280	SCREW M14 x 45 DIN 933 CLASS 8.8	
45	600.626	NUT M14 DIN 982 CLASS 6	

TABLE 02 SB

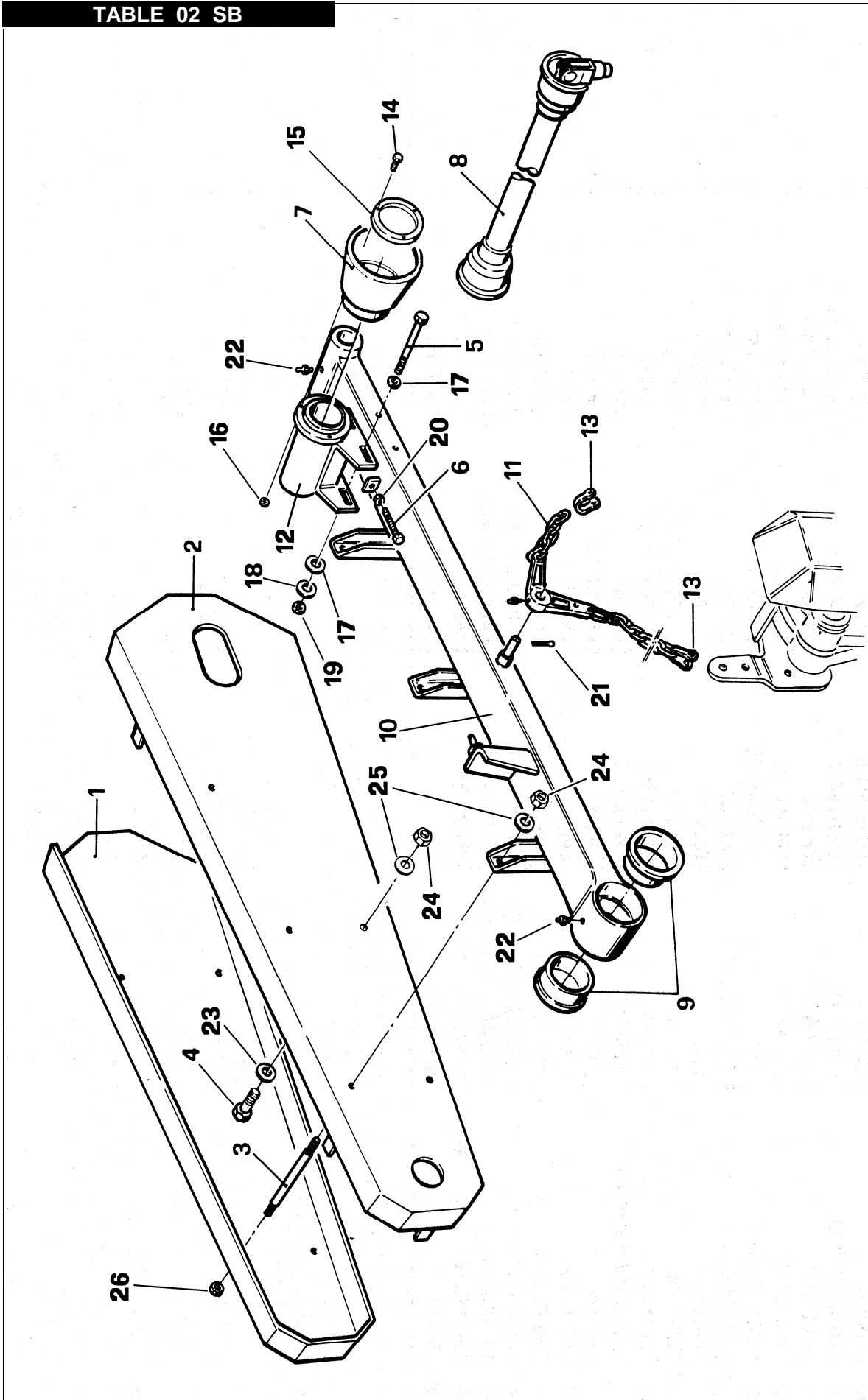

TAB. 02 SB			
ITEM	PART.NO	DESCRIPTION	NOTE
1	100.393	COVER	
2	100.394	CASING	
3	100.395	STUD	
4	600.223	SCREW M8x20 DIN 933 CLASS 8.8	
5	610.612	SCREW M14x140 DIN 931 CLASS 8.8	
6	600.386	SCREW M12x70 DIN 933 CLASS 8.8	
7	610.614	BELLOW	
8	610.172	SHAFT	
9	100.396	BUSH	
10	100.397	FRAME	
11	100.398	ROCHER BRACKET	
12	100.399	SUPPORT	
13	610.118	THIMBLE	
14	600.236	SCREW M6x20 DIN 933 CLASS 4.8	
15	100.519	WASHER	
16	600.472	NUT M6 DIN 980 CLASS 8	
17	600.188	WASHER D. 15 DIN 125A	
18	600.086	WASHER D. 15 UNI 1751A	
19	610.688	NUT M14 UNI 5587 CLASS 8	
20	600.624	NUT M12 UNI 5587 CLASS 8	
21	600.038	SPLIT PIN 6x35 DIN 94	
22	600.034	GREASE NIPPLE M8	
23	600.115	WASHER D. 8.4 DIN 125A	
24	600.229	WASHER D. 8.4 UNI 1751A	
25	600.037	NUT M8 DIN 934 CLASS 8	
26	600.652	NUT M8 DIN 985 CLASS 6	

TABLE 03 SB

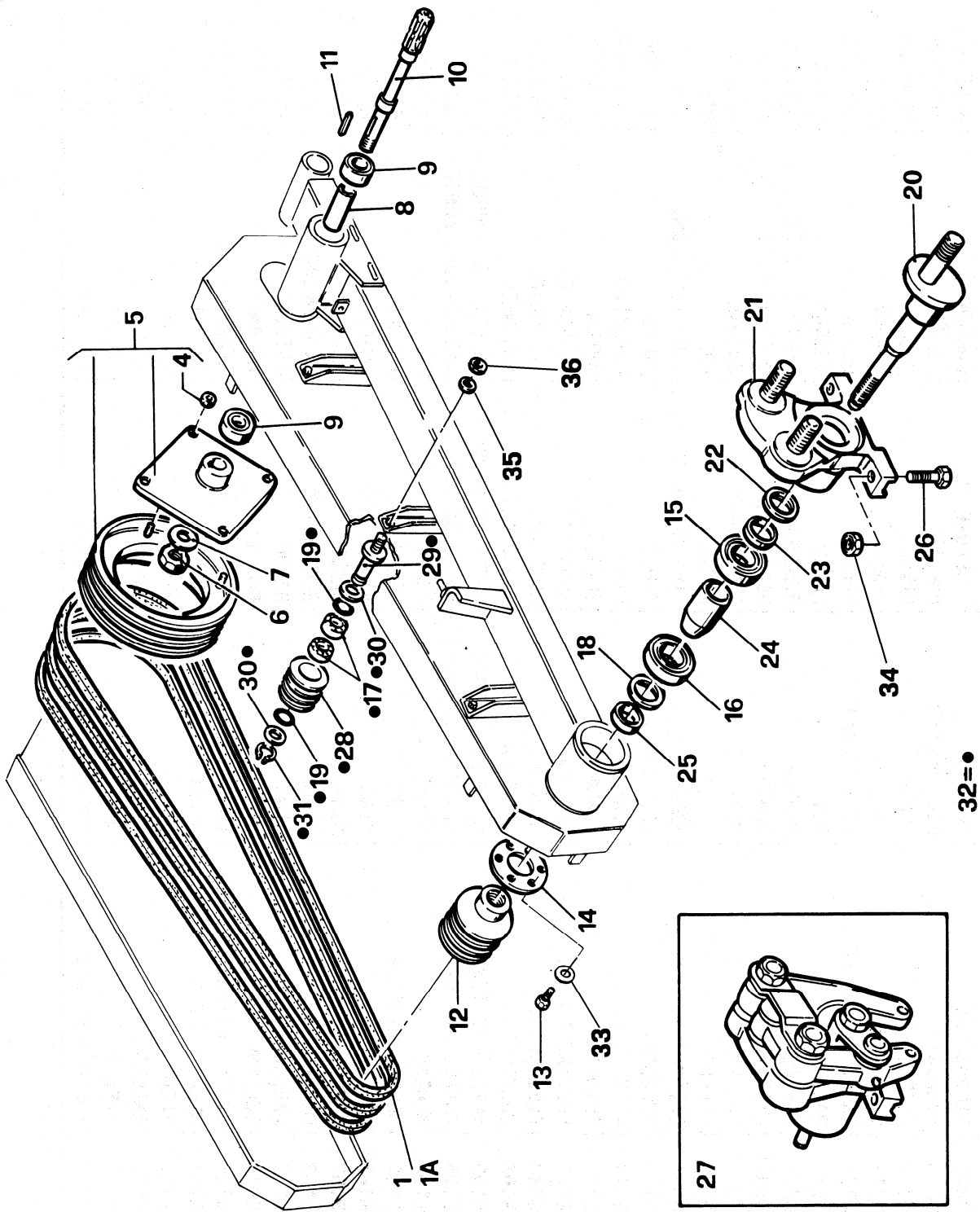

32=●

TAB. 03 SB			
ITEM	PART.NO	DESCRIPTION	NOTE
1	610.617	BELT	
4	100.402	SPECIAL NUT	
5	100.403	BELT PULLEY	
6	610.618	SPECIAL NUT	
7	610.619	WASHER	
8	100.404	SPACER	
9	600.608	BEARING 6207 2RS	
10	100.405	SHAFT	
11	610.621	KEY B 8x7x56 DIN 6885	
12	100.406	BELT PULLEY	
13	600.702	SCREW M8x25 DIN 933 CLASS 8.8	
14	100.407	FLANGE	
15	610.623	BEARING NU 2210	
16	610.624	BEARING 6307 2RS	
17	610.625	BALL BEARING 6003 2RS	NEW TYPE
17	610.692	NEEDLE ROLLER BEARING HK 2012	OLD TYPE
18	610.626	CLAMPING WASHER	
19	610.627	CLAMPING WASHER	
20	100.408	SHAFT	
21	100.409	BODY	
22	100.410	RING	
23	100.411	RING	
24	100.412	SPACER	
25	100.413	RING	
26	610.628	SCREW M16x1.5x110 DIN 960 CLASS 8	
27	100.414	BODY	
28	100.415	PULLEY	
29	100.416	PIN	
30	100.417	RING	
31	610.629	SNAP RING E 17 DIN 471	
32	100.418	ROLLER	
33	600.229	WASHER D. 8.4 UNI 1751A	
34	610.691	NUT M16x1.5 DIN 982 CLASS 6	
35	600.086	WASHER D. 15 UNI 1751A	
36	610.690	SPECIAL NUT	

TABLE 04 SB

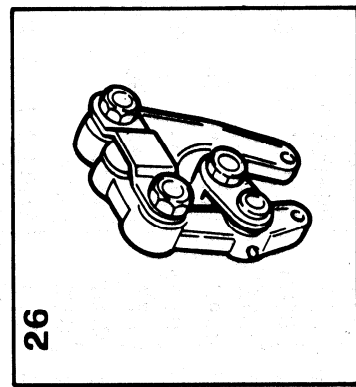
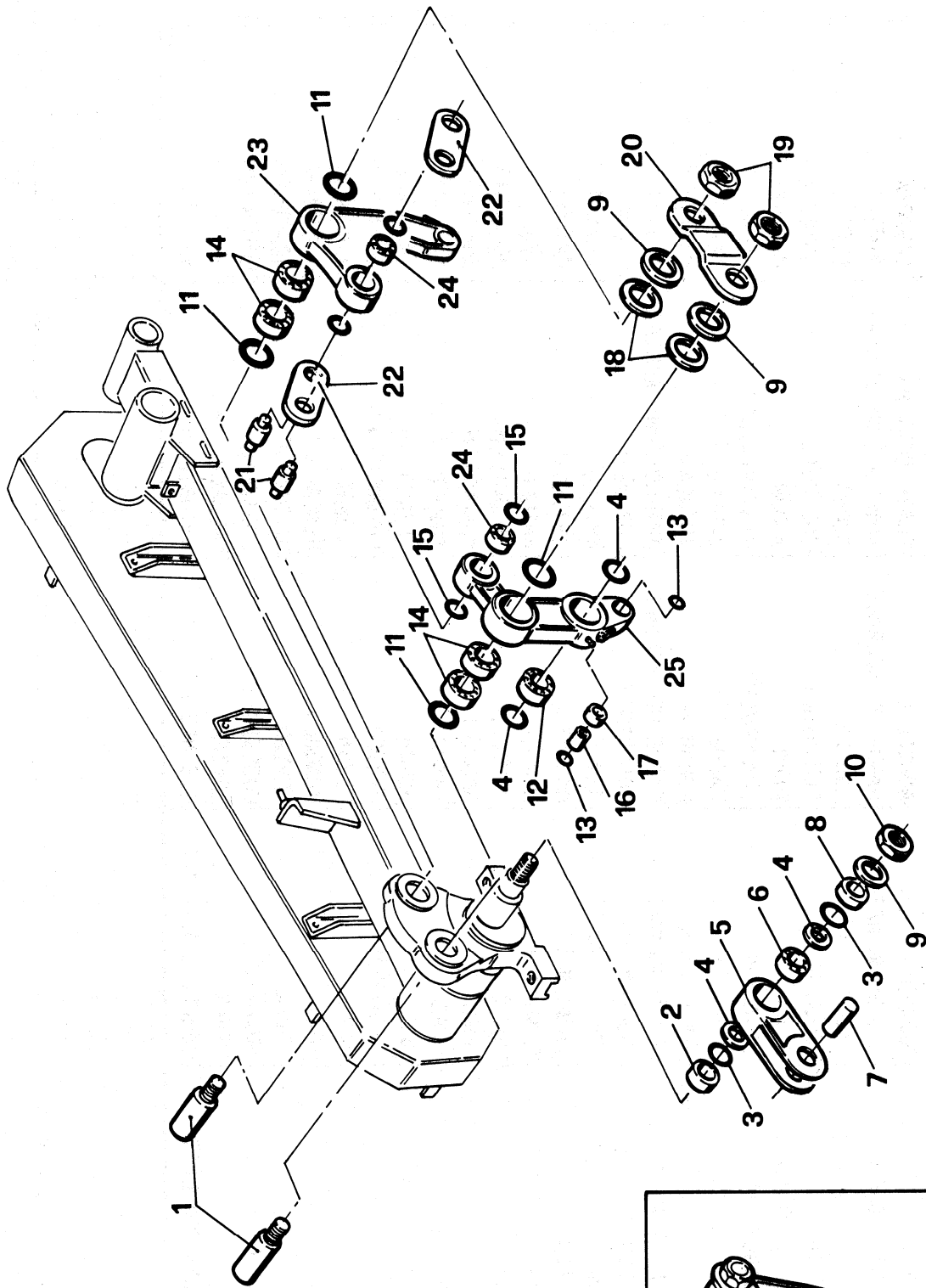

TAB. 04 SB			
ITEM	PART.NO	DESCRIPTION	NOTE
1	100.419	PIN	
2	100.420	SPACER	
3	100.421	WASHER	
4	610.630	CLAMPING WASHER	
5	100.422	ROD	
6	610.631	BEARING NA 6932 AC4	
7	100.423	PIN	
8	100.424	SPACER	
9	100.425	RING	
10	610.632	SPECIAL NUT	
11	610.633	CLAMPING WASHER	
12	610.634	SPECIAL BEARING	
13	610.635	RING	
14	610.636	BEARING HK 4020	
15	100.426	RING	
16	100.427	BUSH	
17	100.428	BUSH	
18	610.637	RING	
19	610.638	SPECIAL NUT	
20	100.429	PLATE	
21	100.430	PIN	
22	100.431	PLATE	
23	100.432	LEVER	
24	610.639	BEARING HK 3026 VAS1	
25	100.433	LEVER	
26	100.434	CONNECT. ROD KIT	

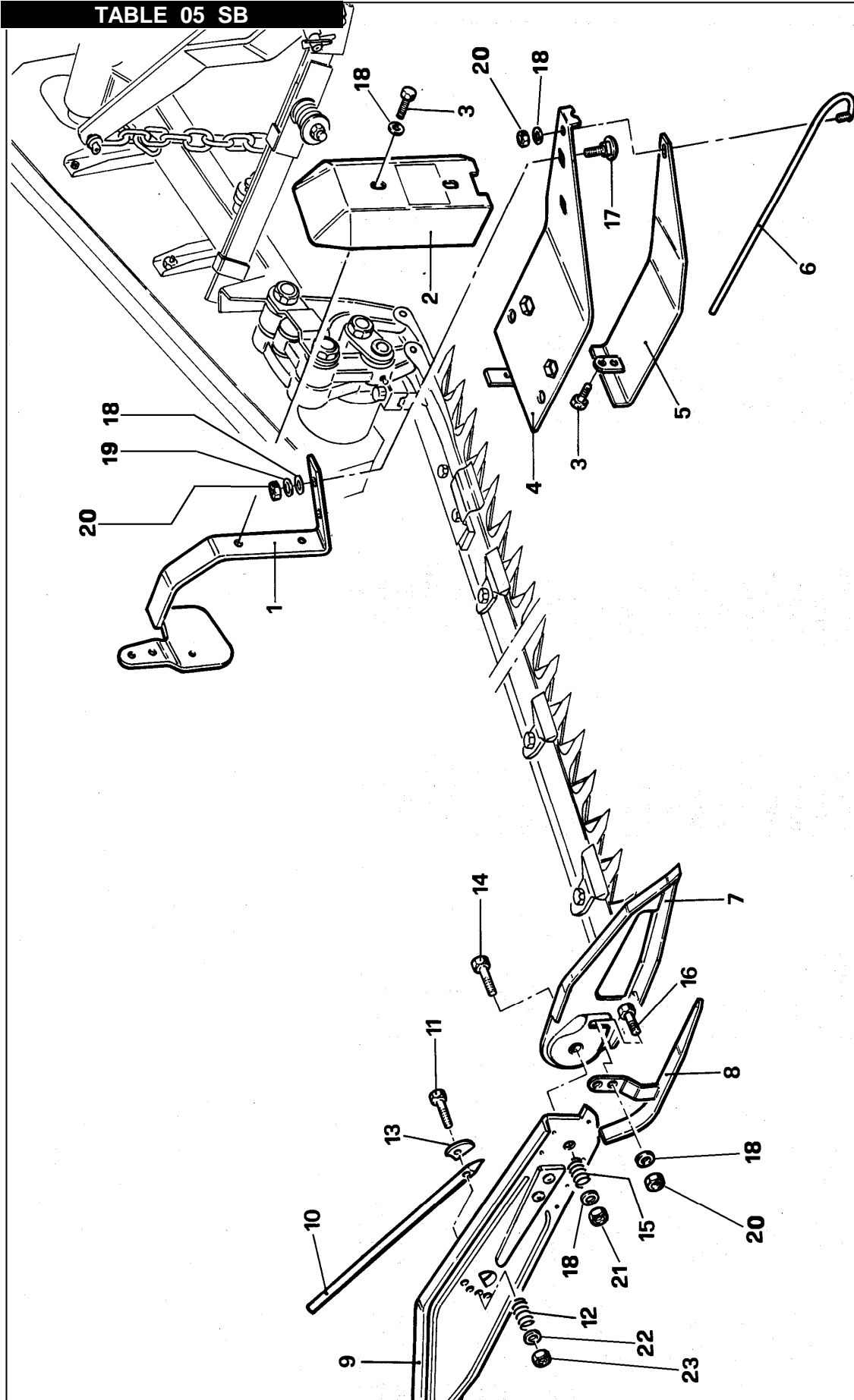

TAB. 05 SB			
ITEM	PART.NO	DESCRIPTION	NOTE
1	100.435	SUPPORT	
2	100.436	CASING	
3	600.770	SCREW M12x20 UNI 5739 CLASS 8.8	
4	100.437	SHOE	
5	100.438	SOLE	
6	100.439	ROD	
7	100.469	SHOE	
8	100.441	SOLE	
9	100.443	OUTER SWATH BOARD	
10	100.445	SWATH STICK	
11	610.641	SCREW M8x70 DIN 603 CLASS 6.8	
12	100.447	SPRING	
13	100.448	FASTENINGS	
14	600.210	SCREW M12x70 UNI 5737 CLASS 8.8	
15	100.449	SPRING	
16	610.643	SPECIAL SCREW	
17	610.644	SPECIAL SCREW	
18	600.089	WASHER D. 13 DIN 125A	
19	600.018	WASHER D. 13 UNI 1751	
20	600.624	NUT M12 UNI 5587 CLASS 8	
21	600.077	NUT M12 DIN 980 CLASS 8	
22	600.115	WASHER	
23	610.693	NUT M8 UNI 7473	

TABLE 08 SB

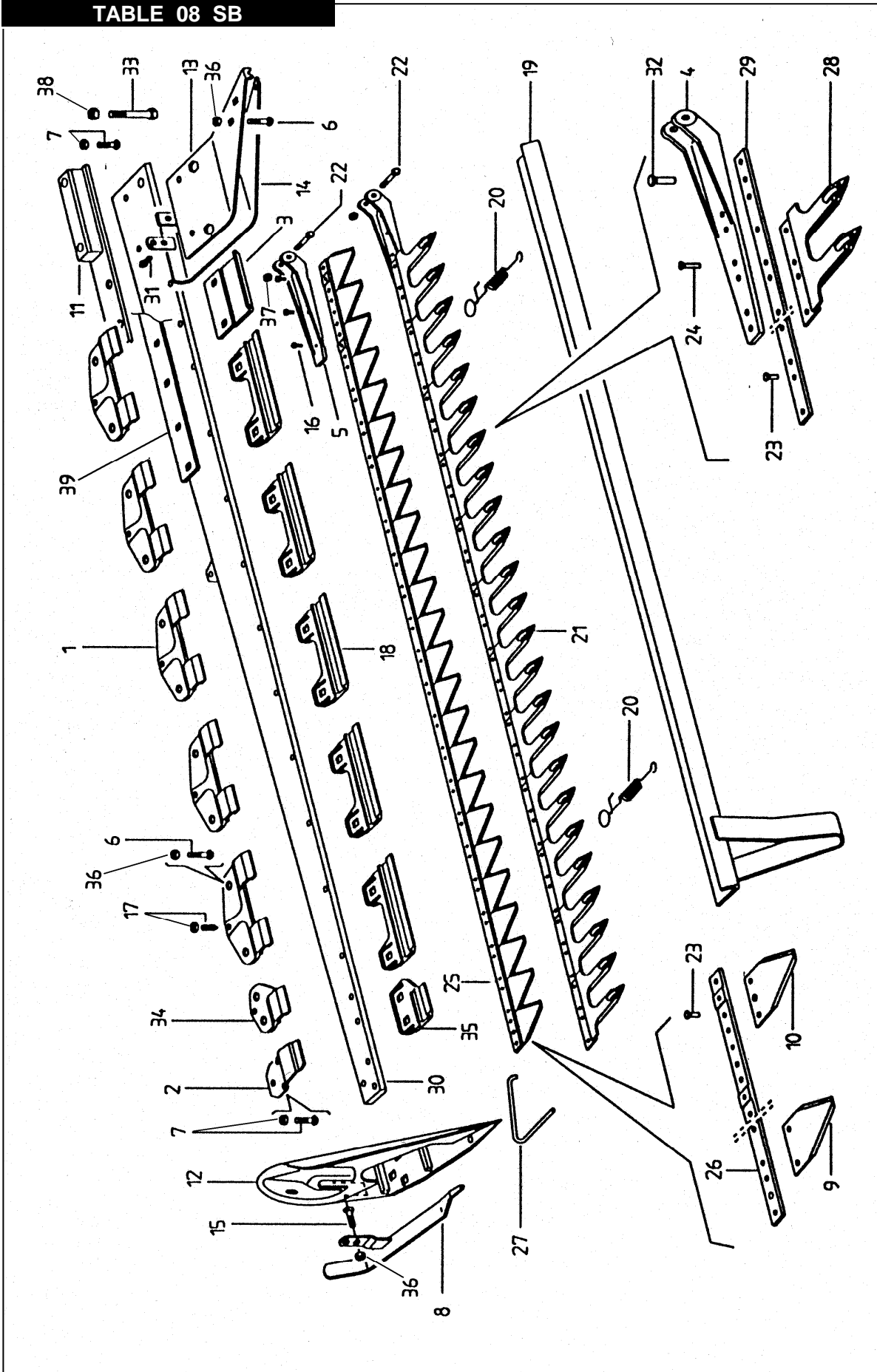

TAB. 08 SB			
ITEM	PART.NO	DESCRIPTION	NOTE
1	100.459	BLADE HOLDER	
2	100.460	BLADE HOLDER	
3	100.461	GUIDE	
4	100.462	BLADE HEAD	
5	100.463	BLADE HEAD	
6	610.644	SPECIAL SCREW	
7	610.656	SPECIAL BOLT	
8	100.441	SOLE	
9	100.464	SECTION	
10	100.466	SECTION 3 HOLES	
11	100.468	STIFFENER	
12	100.469	OUTER SHOE	
13	100.437	INNER SHOE	
14	100.438	INNER SOLE	
15	610.643	SPECIAL SCREW	
16	610.657	SPECIAL BOLT	
17	610.658	SPECIAL SCREW	
18	100.470	GUIDE	
19	100.592	LINER	SB 150
19	100.472	LINER	SB 165
19	100.473	LINER	SB 180
19	100.474	LINER	SB 210
20	100.475	SPRING	
21	100.593	BLADE 150	
21	100.477	BLADE 165	
21	100.478	BLADE 180	
21	100.479	BLADE 210	
22	610.659	SPECIAL SCREW	
23	100.480	RIVET 5X13	
24	100.481	RIVET 5X22	
25	100.581	BLADE 150	
25	100.483	BLADE 165	
25	100.484	BLADE 180	
25	100.485	BLADE 210	
26	100.589	DRILLER BAR 150	
26	100.487	DRILLER BAR 165	
26	100.488	DRILLER BAR 180	
26	100.489	DRILLER BAR 210	
27	100.490	HAULAGE HOOK	
28	100.491	KNIFE TOOTH	
29	100.590	DRILLER BAR 150	
29	100.493	DRILLER BAR 165	
29	100.494	DRILLER BAR 180	
29	100.495	DRILLER BAR 210	
30	100.591	CUTTER BAR 150	
30	100.497	CUTTER BAR 165	
30	100.498	CUTTER BAR 180	
30	100.499	CUTTER BAR 210	
31	600.770	SCREW M12x20 DIN 933 CLASS 8.8	
32	100.500	RIVET 7X24	
33	610.628	SCREW M16x1.5x110 DIN 960 CLASS 8	
34	100.501	BLADE HOLDER	
35	100.502	GUIDE	
36	600.624	NUT M12 UNI 5587 CLASS 8	
37	600.077	NUT M12 DIN 980 CLASS 8	
38	610.691	NUT M16x1.5 DIN 982 CLASS 8	
39	100.675	REINFORCEMENT PLATE	SB 180/210

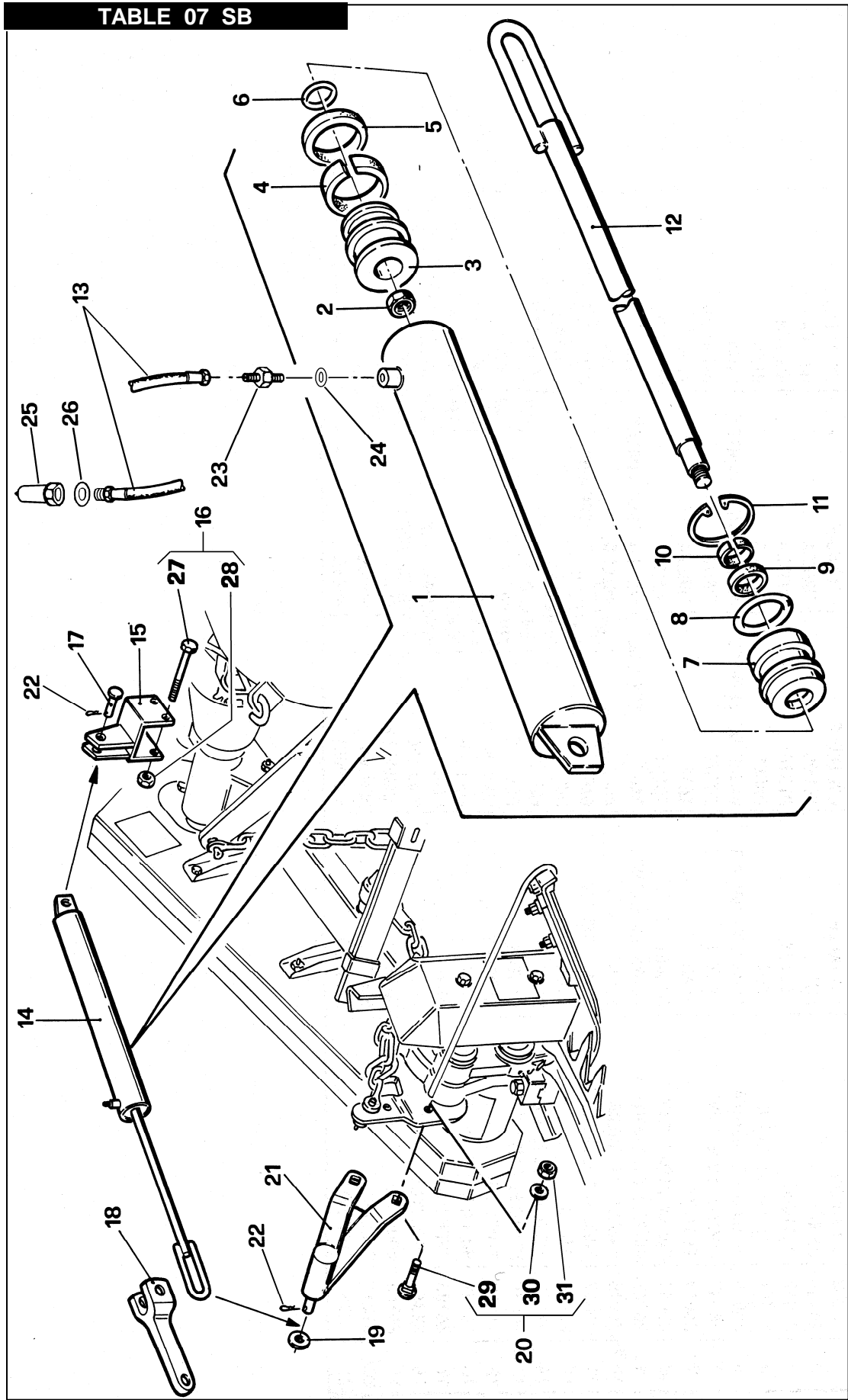

TAB. 07 SB			
ITEM	PART.NO	DESCRIPTION	NOTE
1	100.451	CYLINDER BARREL	
2	610.646	NUT	
3	100.453	PISTON	
4 (**)	610.028	RING	
6 (**)	610.029	GASKET	
7	210.288	HEAD	
8 (**)	610.026	GASKET	
9 (**)	610.027	CLAMPING WASHER	
10 (**)	610.025	RING	
12	100.456	STEM	
13	610.437	HOSE	
14	100.344	CYLINDER	
15	100.341	SUPPORT	
16	610.654	BOLT	
17	100.343	PIN	
18	100.342	EXTENSION	
19	600.632	WASHER	
20	610.655	BOLT	
21	100.340	SUPPORT	
22	600.038	SPLIT PIN	
23	600.270	NIPPLES	
24	600.039	COPPER WASHER	
25	600.273	RAPID COUPLING	
26	600.269	COPPER WASHER	
27	610.282	SCREW M10x130 DIN 931 CLASS 8.8	
28	600.029	NUT M10 DIN 980 CLASS 8	
29	610.438	SCREW M12x40 DIN 603 CLASS 6.8	
30	600.634	WASHER D. 12.5 DIN 6798A	
31	600.077	NUT M12 DIN 980 CLASS 8	
*	100.345	KIT COplete (ALL ITEMS TAB.07 SB)	
(**)	600.895	SET OF GASKET	

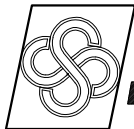

AGRICULTURAL MACHINERY
sitrex® SpA .

Zona Industriale-Viale Grecia, 8
06018 TRESTINA-(Perugia)-ITALY
Tel. +39.075.8540021-Telefax +39.075.8540523
e-mail: sitrex@sitrex.it www.sitrex.com

