

AGRICULTURAL MACHINERY

sitrex®
Spa

SPARE PARTS LIST

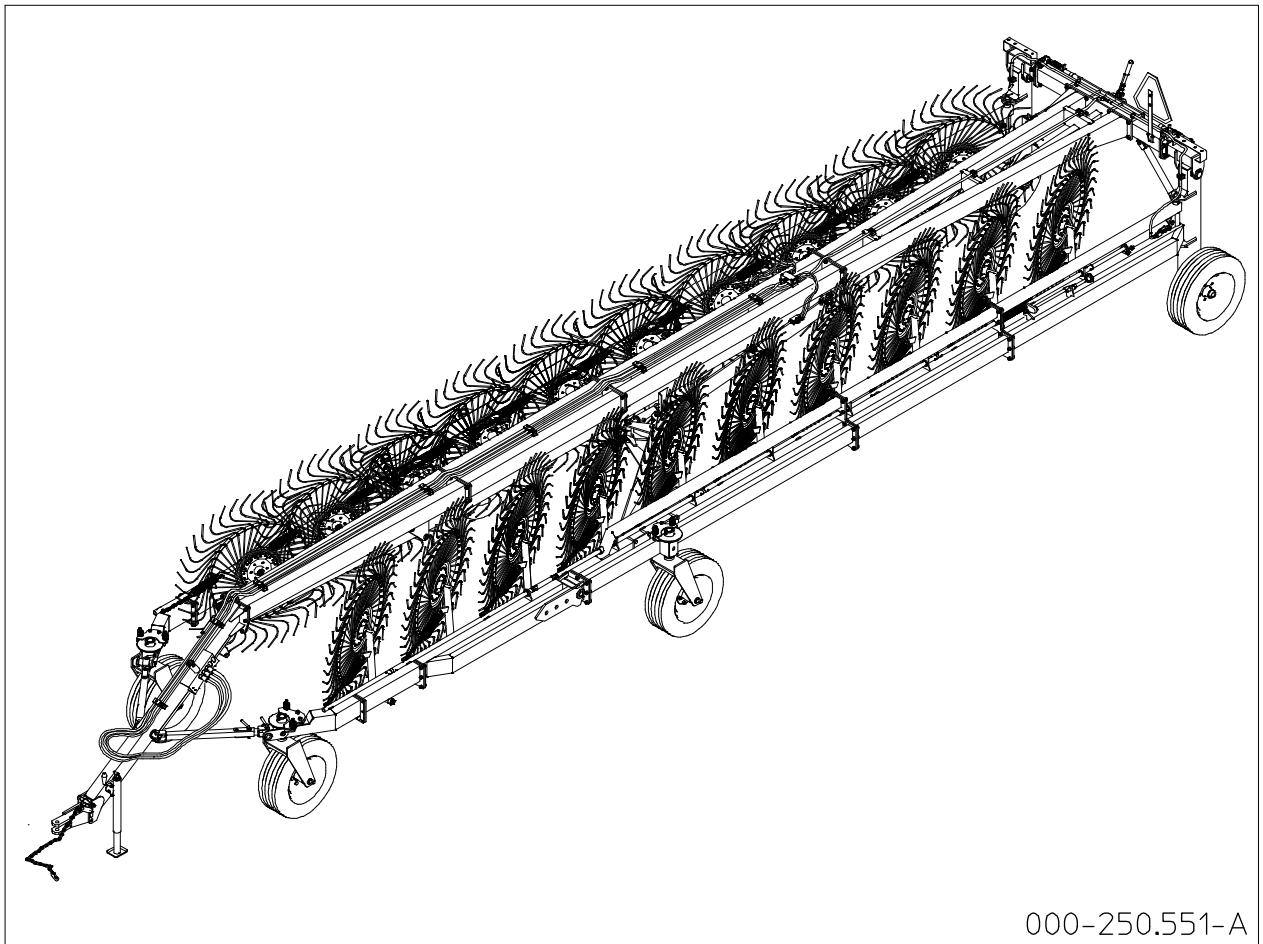

MKE/18-20

09/2016

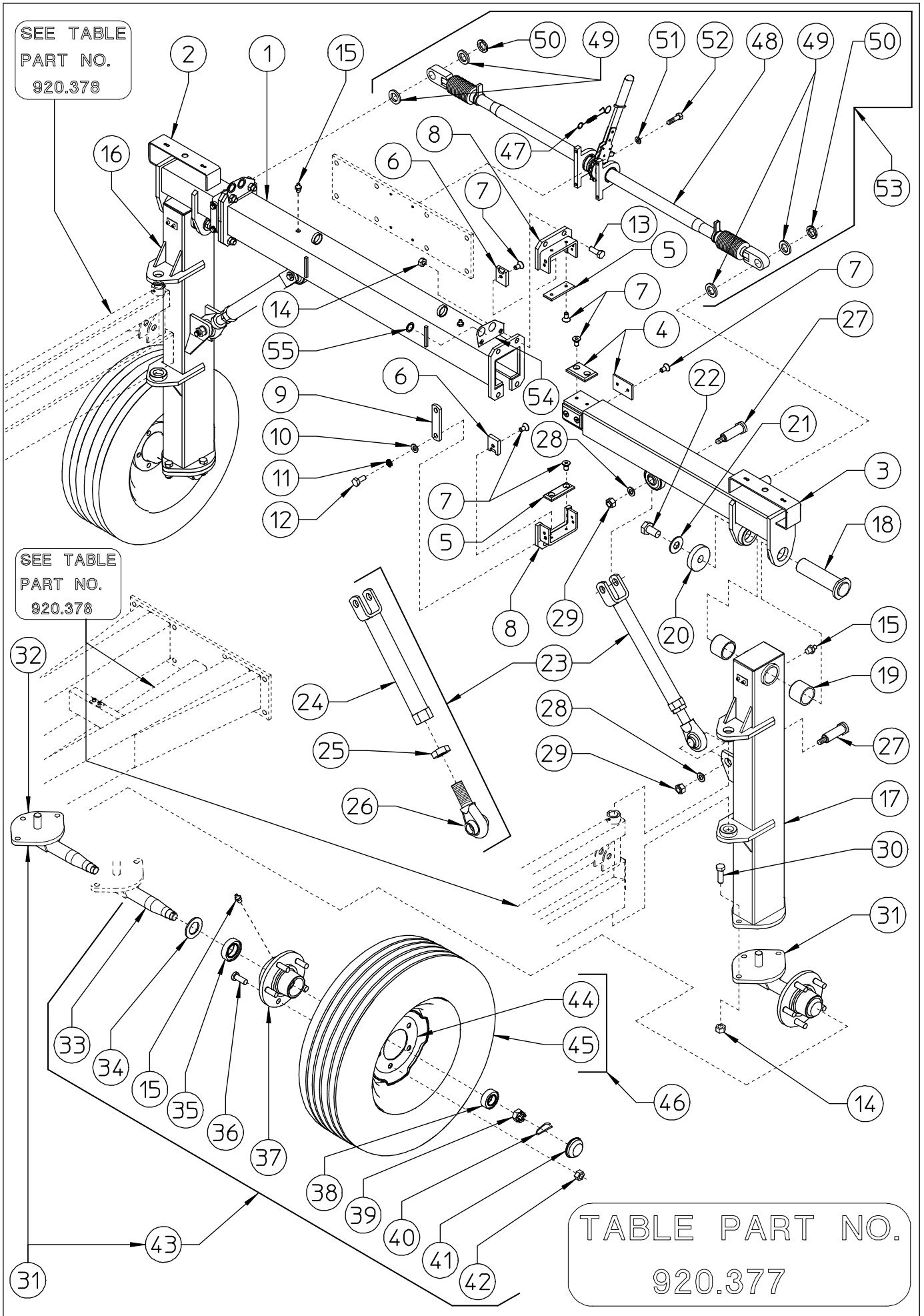
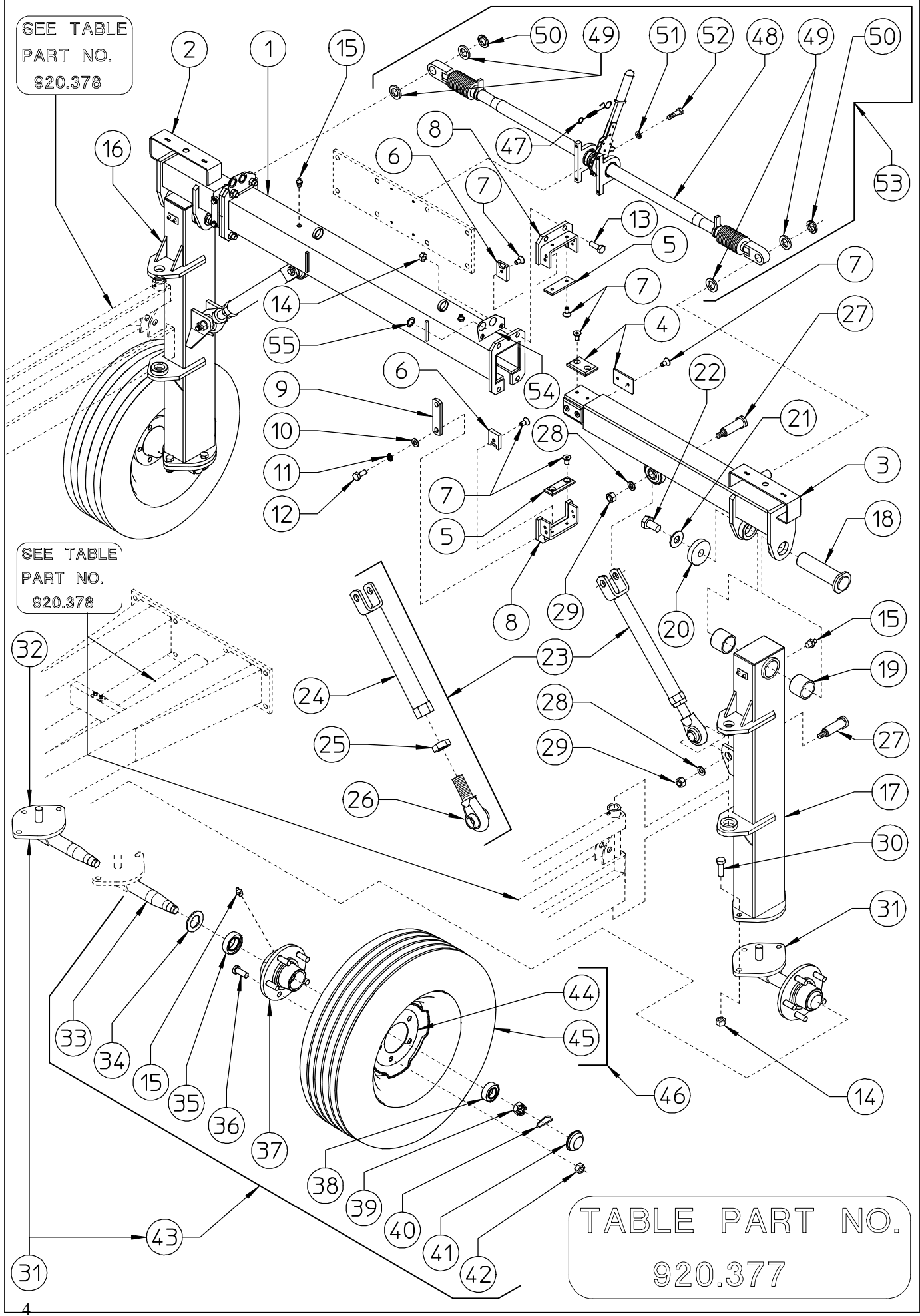

TABLE PART NO 920.377 - REAR PART (18-20 WHEELS)

ITEM	Q.ty MKE/18	Q.ty MKE/20	SITREX PART NO	DESCRIPTION	NOTE
1	1	1	220.177	OUTER CROSSPIECE	
2	1	1	250.211	RH CROSSPIECE	
3	1	1	250.212	LH CROSSPIECE	
4	6	6	210.858	SLIDING	
	2	2	260.929	SLIDING WITH SLOT	
5	4	4	210.911	SLIDING	
6	8	8	210.912	SLIDING	
7	32	32	610.663	SCREW M8 x 16 DIN 7991 8.8	
8	4	4	220.042	SLIDING SUPPORT	
9	4	4	220.043	LINKING PLATE	
10	8	8	600.322	WASHER D 10,5 DIN 433	
11	8	8	600.024	SPRING WASHER D 10.5 DIN 127B	
12	8	8	600.006	SCREW M10 X 25 DIN 933 8.8	
13	8	8	610.167	SCREW M16 X 45 DIN 933 8.8	
14	14	14	600.080	NUT M16 DIN 980	
15	6	6	600.034	GREASE NIPPLE M8	
16	1	1	250.213	REAR WHEEL SUPPORT,RH	
17	1	1	250.214	REAR WHEEL SUPPORT,LH	
18	2	2	210.100	PIN ø50	
19	4	4	200.199	NYLON BUSH ø50-60	
20	2	2	200.822	WASHER ø23-75 x 12	
21	2	2	600.214	SPRING WASHER ø23 DIN 127 B	
22	2	2	600.150	SCREW M22 X 50 DIN 933 8.8	
23	2	2	250.215	TIE ROD, COMPLETE	
24	2	2	250.216	TIE ROD PIPE	
25	2	2	610.813	NUT M30 DIN 936	
26	2	2	250.217	TIE ROD HEAD	
27	4	4	250.218	PIN ø25	
28	4	4	600.845	WASHER ø12-36x4	
29	4	4	600.077	NUT M12 DIN 980	
30	6	6	600.384	SCREW M16 X 50 DIN 933 8.8	

SEE TABLE
PART NO.
920.378



SEE TABLE
PART NO.
920.378

TABLE PART NO.
920.377

TABLE PART NO 920.377 - REAR PART (18-20 WHEELS)

ITEM	Q.ty MKE/18	Q.ty MKE/20	SITREX PART NO	DESCRIPTION	NOTE
31	2	2	250.219	HUB ASSY	
32	2	2	250.220	FLANGE WITH PIN	
33	2	2	215.781	PIN ONLY	
34	2	2	600.284	DUST COVER	
35	2	2	600.285	BEARING 30208	
36	10	10	610.413	SCREW M16x1,5x50	
37	2	2	600.286	HUB WITH SCREWS	
38	2	2	600.287	BEARING 30206	
39	2	2	600.288	CASTLE NUT M27 X 1,5	
40	2	2	600.291	SPLIT PIN ø3	
41	2	2	600.290	CAP	
42	10	10	600.289	NUT M16x1,5	
43	2	2	215.782	HUB WITHOUT FLANGE	
44	2	2	600.304	RIM 6Jx15	
45	2	2	600.303	TIRE 205/75-15	
46	2	2	600.281	WHEEL ASSY	
47	1	1	220.378	LOCK SPRING	
48	1	1	210.981	RATCHET LINK	
49	4	4	220.208	SHIM ø30,5-50x6	
50	2	2	610.593	LOCK-NUT M30 X 1,5	
51	4	4	600.229	SPRING WASHER ø8,5 DIN 127B	
52	4	4	600.757	SCREW M8 X 30 DIN 933 8.8	
53	1	1	220.260	RATCHET LINK, COMPLETE KIT	
54	2	2	250.409	HOSE SUPPORT	
55	4	4	631.711	GASKET	

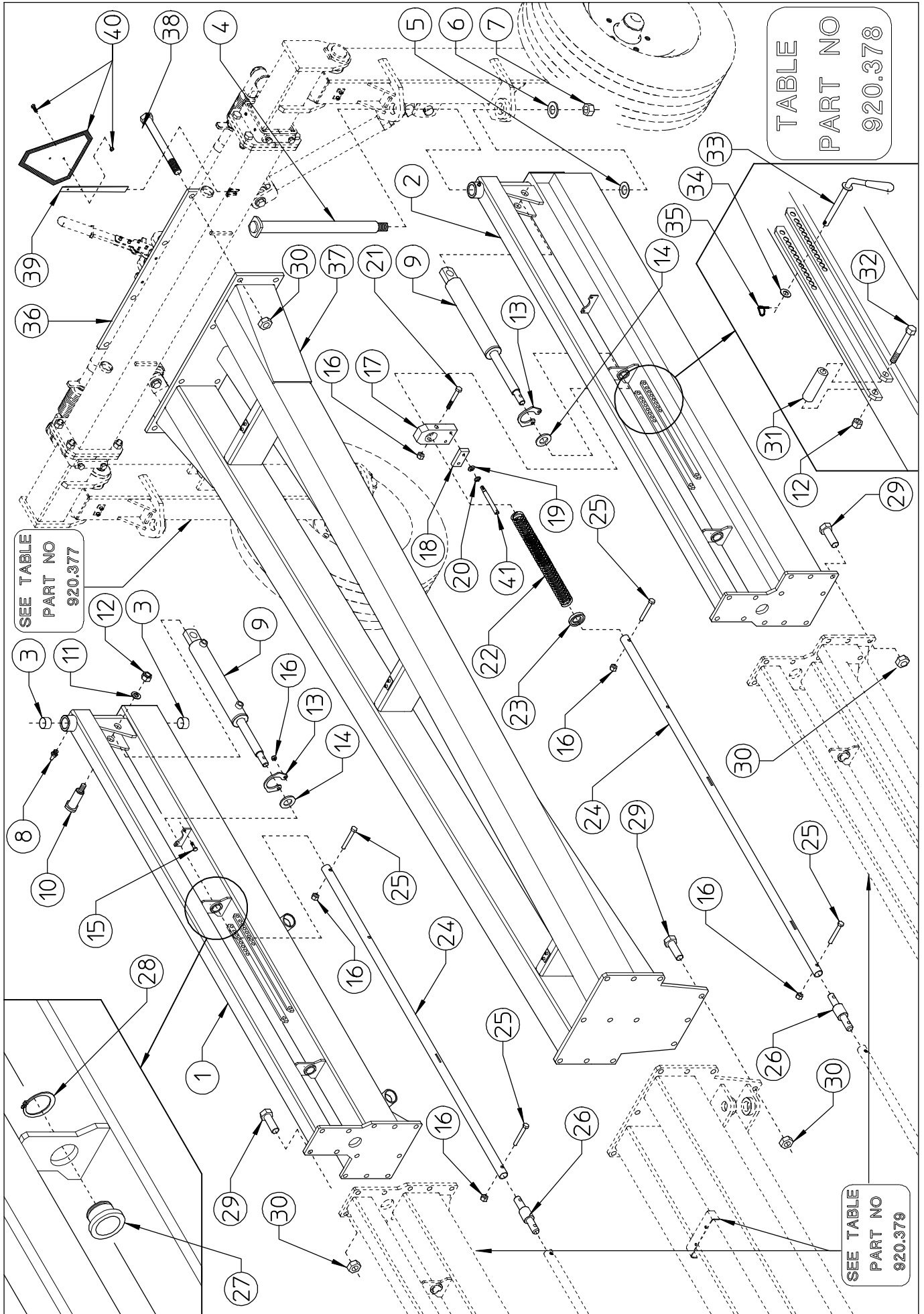

TABLE PART NO 920.378 - REAR SECTIONS AND DRAWBAR (18-20 WHEELS)

ITEM	Q.ty MKE/18	Q.ty MKE/20	SITREX PART NO	DESCRIPTION	NOTE
1	1	1	250.552	RH SECTION	
2	1	1	250.553	LH SECTION	
3	4	4	640.024	BUSH ø35-39x30	
4	2	2	250.294	PIN ø35	
5	2	2	200.475	SHIM ø35,2-51,8x1,5	
6	2	2	200.165	WASHER ø23-50x4	
7	2	2	600.079	NUT M22 DIN 980	
8	2	2	600.034	GREASE NIPPLE M8	
9	2	2	250.238	CILINDER ø50-60 ROD ø30	
10	2	2	250.240	PIN ø25	
11	2	2	600.845	WASHER ø12-36x4	
12	4	2	600.077	NUT M12 DIN 980	
13	2	2	220.526	CYLINDER LOCKING PLATE	
14	2	2	250.241	SHIM ø25,25-35x4	
15	4	4	600.702	SCREW M8x25 DIN 931 8.8	
16	10	10	600.076	NUT M8 DIN 980	
17	2	2	250.242	SUPPORT	
18	2	2	250.243	SLIDING	
19	4	4	600.115	WASHER ø8,4 DIN 125A	
20	4	4	600.229	SPRING WASHER ø8,5 DIN 127B	
21	2	2	610.525	SCREW M8x60 DIN 931 8.8	
22	2	2	250.244	SPRING ø6 L.600-23,6"	
23	2	2	250.245	BUSH ø34,5-50-60 x 20	
24	2	2	250.246	PIPE ø33,7x4 L.1670-65,75"	
25	4	4	600.551	SCREW M8x45 DIN 931 8.8	
26	2	2	250.266	PIN ø25-35	
27	4	4	250.250	NYLON BUSH ø34,5	
28	4	4	630.957	SNAP RING E42 DIN 471	
29	36	36	610.167	SCREW M16x45 DIN 933 8.8	
30	44	44	600.080	NUT M16 DIN 980	
31	2	2	250.251	BUSH ø12,5-20	
32	2	2	600.007	SCREW M12x85 DIN 931 8.8	
33	2	2	250.252	HANDLE	
34	2	2	600.089	WASHER ø13 DIN 125A	
35	2	2	600.723	SPLIT PIN ø4,5	
36	1	1	250.562	DRAWBAR COUNTERPLATE	
37	1	1	250.563	REAR DRAWBAR	
38	8	8	610.839	SCREW M16x165 DIN 931 8.8	
39	1	1	220.413	SUPPORT	
40	1	1	220.414	SMV EMBLEME ASAES276.7	
41	4	4	250.365	PIN ø12	

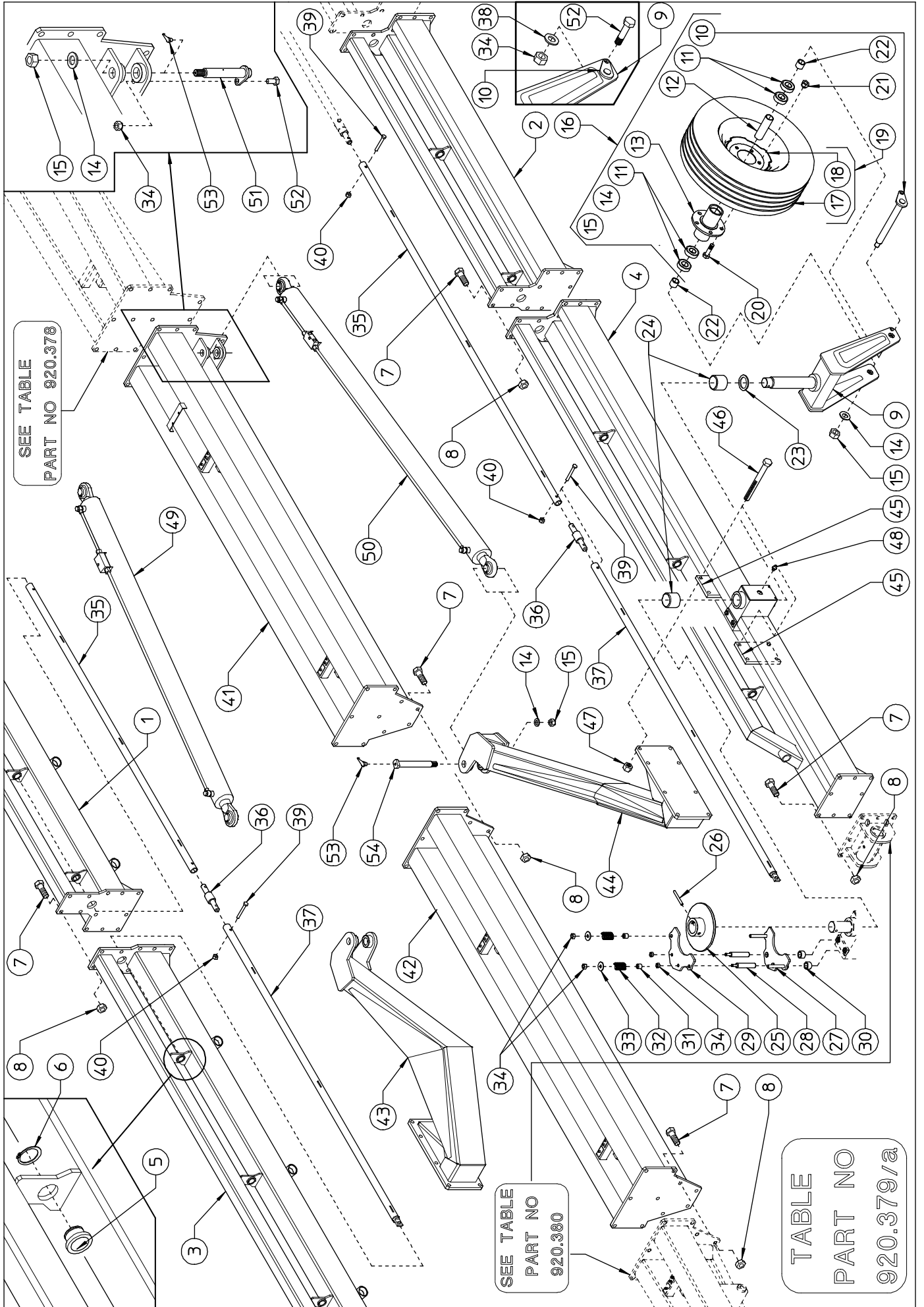

TABLE PART NO 920.379/a - CENTER SECTIONS AND DRAWBAR (18-20 WHEELS)

ITEM	Q.ty MKE/18	Q.ty MKE/20	SITREX PART NO	DESCRIPTION	NOTE
1	1	1	250.554	RH SECTION (2 WHEELS)	
2	1	1	250.555	LH SECTION (2 WHEELS)	
3	1	1	250.556	RH SECTION (3 WHEELS)	
4	1	1	250.557	LH SECTION (3 WHEELS)	
5	10	10	250.250	NYLON BUSH ø34,5	
6	10	10	630.957	SNAP RING E42 DIN 471	
7	58	58	610.167	SCREW M16x45 DIN 933 8.8	
8	58	58	600.080	NUT M16 DIN 980	
9	2	2	250.571	WHEEL SUPPORT	
10	2	2	250.254	PIN ø30	
11	8	8	600.609	BEARING 6206 2RS	
12	2	2	250.210	SPACER	
13	2	2	250.209	HUB	
14	6	6	200.165	WASHER ø23-50x4	
15	6	6	600.079	NUT M22 DIN 980	
16	2	2	250.255	HUB ASSY	
17	2	2	600.303	TIRE 205-75	
18	2	2	600.304	WHEEL RIM 6Jx15	
19	2	2	600.281	COMPLETE WHEEL 205/75-R15	
20	10	10	600.144	SCREW M16x1,5 x 40 DIN 961	
21	10	10	600.289	NUT M16x1,5	
22	4	4	210.170	SPACER	
23	2	2	250.750	SHIM ø55-75x5	
24	4	4	640.121	BUSH ø55-60x50	
25	2	2	200.025	BRAKE FLANGE	
26	2	2	600.033	SPRING PIN ø10x80 DIN 1481	
27	2	2	260.083	BRAKE COUNTERPLATE	
28	4	4	260.092	PIN ø20-M20	
29	2	2	260.082	BRAKE PLATE	
30	4	4	260.091	SHIM ø21-30x10	

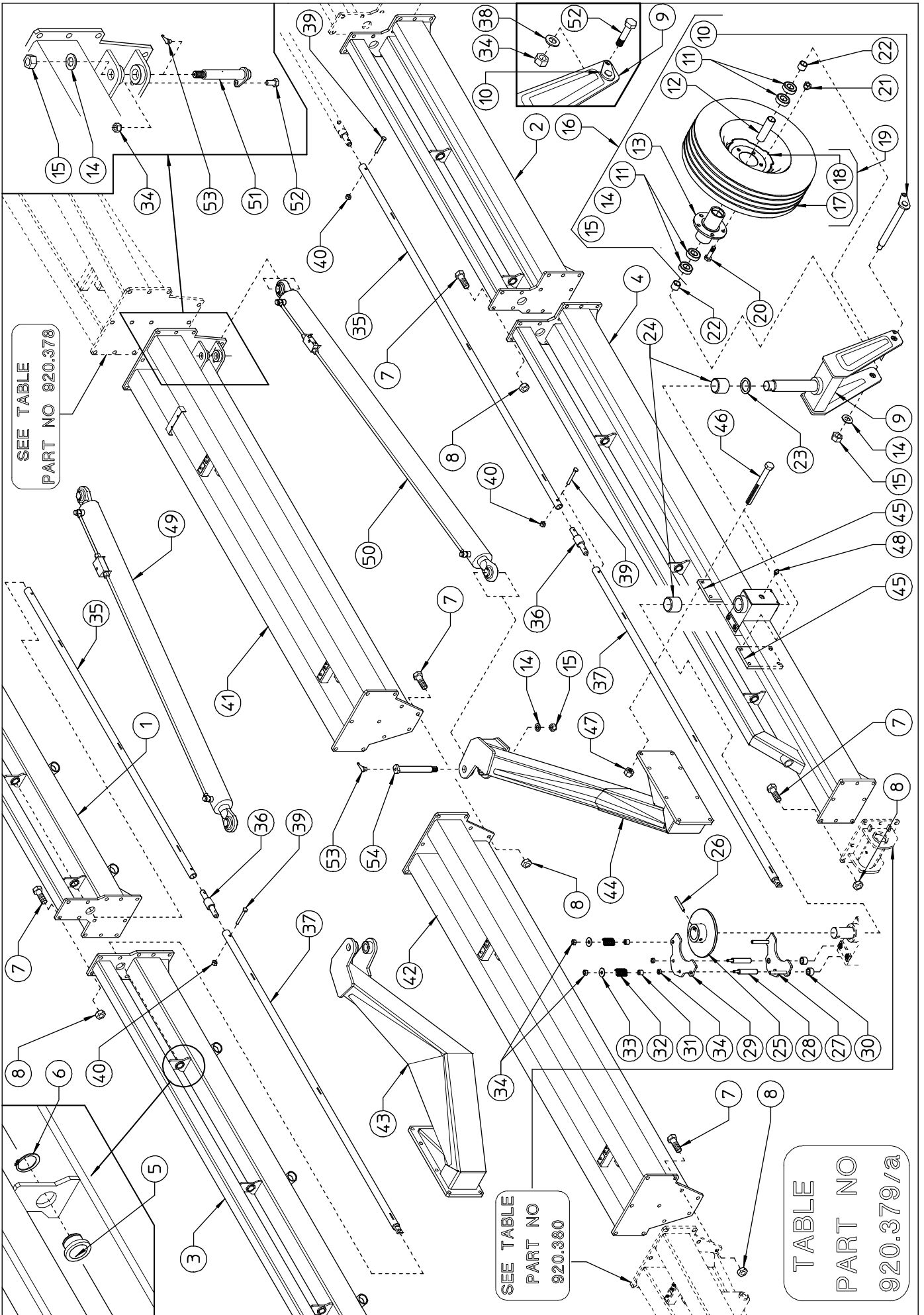

TABLE PART NO 920.379/a - CENTER SECTIONS AND DRAWBAR (18-16 WHEELS)

ITEM	Q.ty MKE/18	Q.ty MKE/20	SITREX PART NO	DESCRIPTION	NOTE
31	4	4	250.259	SPACER	
32	4	4	200.044	SPRING $\phi 5-\phi 30 \times 45$	
33	4	4	600.845	WASHER $\phi 12-36 \times 4$	
34	12	12	600.077	NUT M12 DIN 980	
35	2	2	250.247	PIPE $\phi 33,7$ L.2515-99"	
36	2	2	250.266	PIN $\phi 25-35$	
37	2	2	250.567	PIPE $\phi 33,7$ L.1595-62,8"	
38	2	2	600.089	WASHER $\phi 13$ DIN 125A	
39	6	6	600.551	SCREW M8x45 DIN 931 8.8	
40	6	6	600.076	NUT M8 DIN 980	
41	1	1	250.564	DRAWBAR	
42	1	1	250.565	DRAWBAR	
43	1	1	250.260	RH ARM	
44	1	1	250.261	LH ARM	
45	4	4	250.262	COUNTERPLATE	
46	16	16	610.612	SCREW M14x140 DIN 931 8.8	
47	16	16	600.075	NUT M14 DIN 980	
48	2	2	600.034	GREASE NIPPLE M8	
49	1	1	250.286	RH CYLINDER WITH VALVE	
50	1	1	250.287	LH CYLINDER WITH VALVE	
51	2	2	250.264	PIN $\phi 30$	
52	4	4	600.616	SCREW M12x35 DIN 933 8.8	
53	4	4	600.968	GREASE NIPPLE M6x45°	
54	2	2	250.265	PIN $\phi 30$	

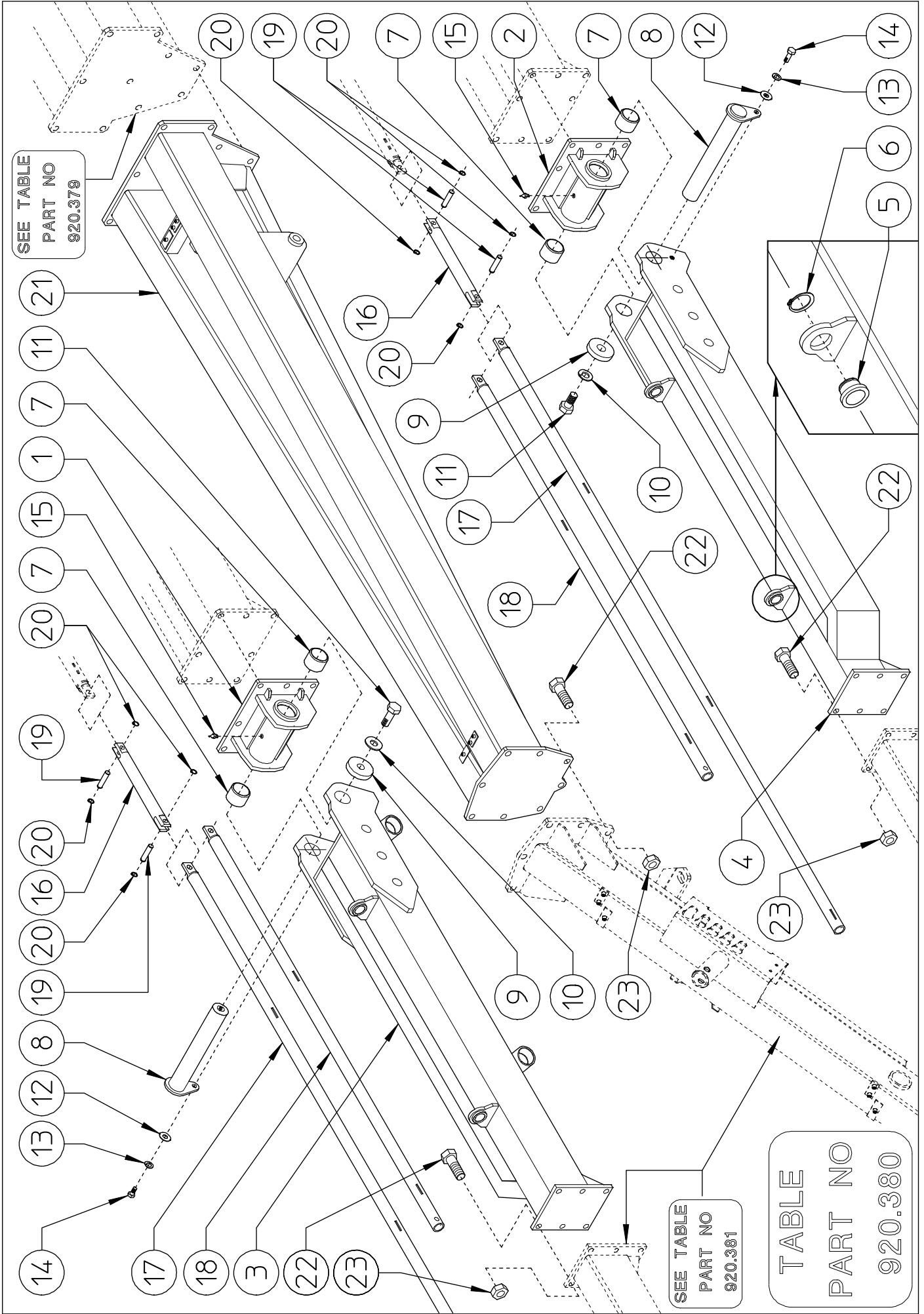
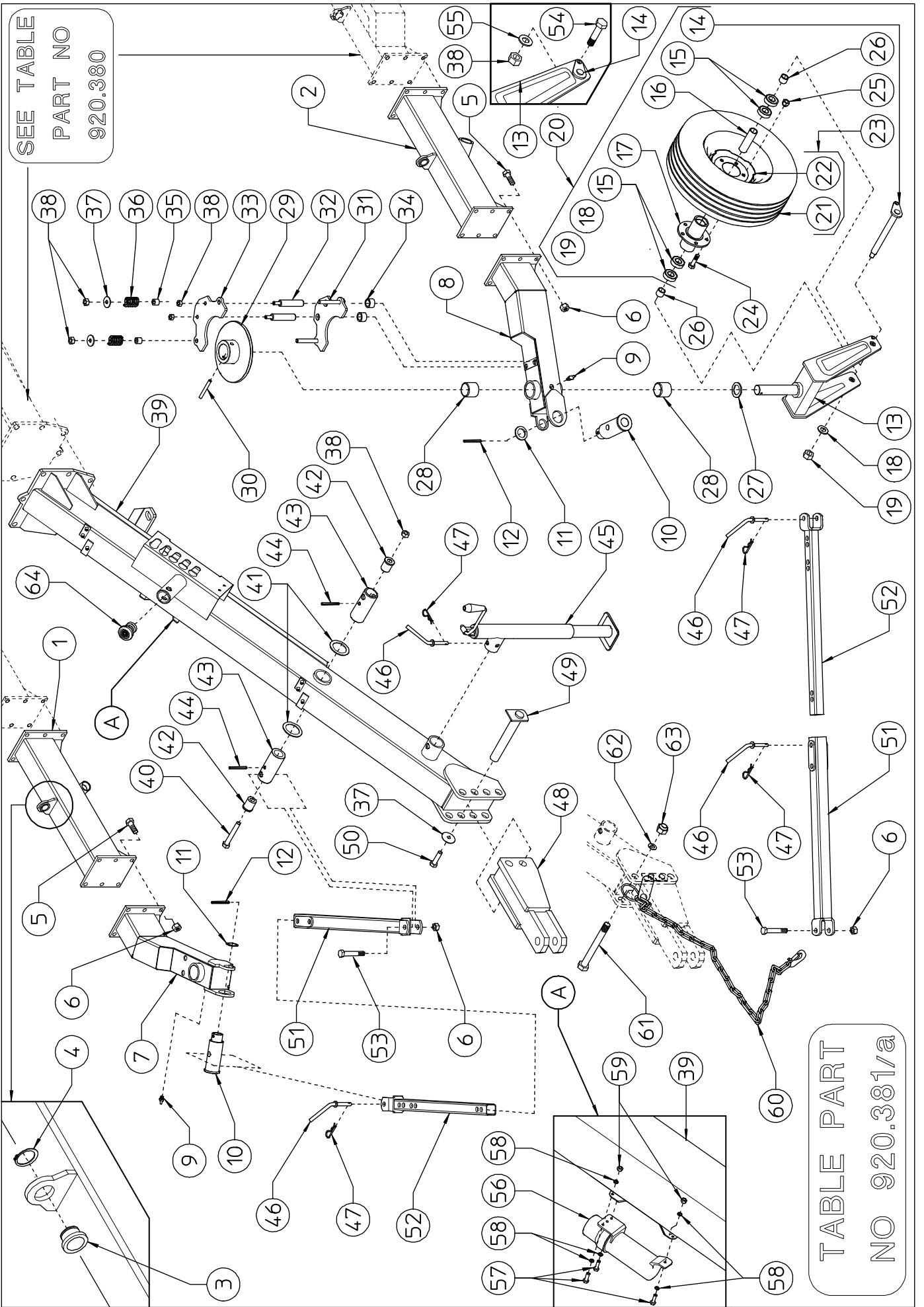

TABLE PART NO 920.380 - JOINT SECTIONS AND DRAWBAR (18-20 WHEELS)					
ITEM	Q.ty MKE/18	Q.ty MKE/20	SITREX PART NO	DESCRIPTION	NOTE
1	1	1	250.558	RH SUPPORT	
2	1	1	250.559	LH SUPPORT	
3	1	1	250.560	RH SECTION (2 WHEELS)	
4	1	1	250.561	LH SECTION (2 WHEELS)	
5	4	4	250.250	NYLON BUSH ø34,5	
6	4	4	630.957	SNAP RING E42 DIN 471	
7	4	4	200.199	NYLON BUSH ø50-60x50	
8	2	2	250.566	PIN ø50	
9	2	2	200.822	SHIM ø23-75x12	
10	2	2	600.214	WASHER ø23 DIN 127B	
11	2	2	600.150	SCREW M22x50 DIN 933 8.8	
12	2	2	600.089	WAHER ø13 DIN 125A	
13	2	2	600.018	SPRING WASHER ø13 DIN 127B	
14	2	2	600.441	SCREW M12x25 DIN 933	
15	2	2	600.034	GREASE NIPPLE M8	
16	2	2	250.570	TIE ROD	
17	*	2	250.568	PIPE L.2310mm - 90,94"	
18	2	*	250.569	PIPE L.1565mm - 61,61"	
19	4	4	200.074	PIN ø15	
20	8	8	600.023	SNAP RING E15 DIN 471	
21	1	1	260.778	DRAWBAR	
22	20	20	610.167	SCREW M16x45 DIN 933 8.8	
23	20	20	600.080	NUT M16 DIN 980	



SEE TABLE
PART NO
920.380

TABLE PART
NO 920.381/a

TABLE PART NO 920.381/a - FRONT SECTIONS AND DRAWBAR (18-20 WHEELS)

ITEM	Q.ty MKE/18	Q.ty MKE/20	SITREX PART NO	DESCRIPTION	NOTE
1	*	1	250.230	RH SECTION (1 WHEEL)	
2	*	1	250.231	LH SECTION (1 WHEEL)	
3	*	2	250.250	NYLON BUSH ϕ 34,5	
4	*	2	630.957	SNAP RING E42 DIN 471	
5	12	12	610.167	SCREW M16x45 DIN 933 8.8	
6	14	14	600.080	NUT M16 DIN 980	
7	1	1	260.105	RH WHEEL SUPPORT	
8	1	1	260.106	LH WHEEL SUPPORT	
9	2	2	600.034	GREASE NIPPLE M8	
10	2	2	250.267	BUSHING	
11	2	2	250.268	SHIM ϕ 39-50x3	
12	2	2	600.027	SPRING PIN ϕ 8x50 DIN 1481	
13	2	2	250.253	WHEEL SUPPORT	
14	2	2	250.254	PIN ϕ 30	
15	8	8	600.609	BEARING 6206 2RS	
16	2	2	250.210	SPACER	
17	2	2	250.209	HUB	
18	2	2	200.165	WASHER ϕ 23-50x4	
19	2	2	600.079	NUT M22 DIN 980	
20	2	2	250.255	HUB ASSY	
21	2	2	600.303	TIRE 205-75	
22	2	2	600.304	WHEEL RIM 6Jx15	
23	2	2	600.281	COMPLETE WHEEL 205/75-R15	
24	10	10	600.144	SCREW M16x1,5 x 40 DIN 961	
25	10	10	600.289	NUT M16x1,5	
26	4	4	210.170	SPACER	
27	2	2	210.179	SHIM ϕ 50-75x5	
28	4	4	200.199	NYLON BUSH ϕ 50-60x50	
29	2	2	200.025	BRAKE FLANGE	
30	2	2	600.033	SPRING PIN ϕ 10x80 DIN 1481	

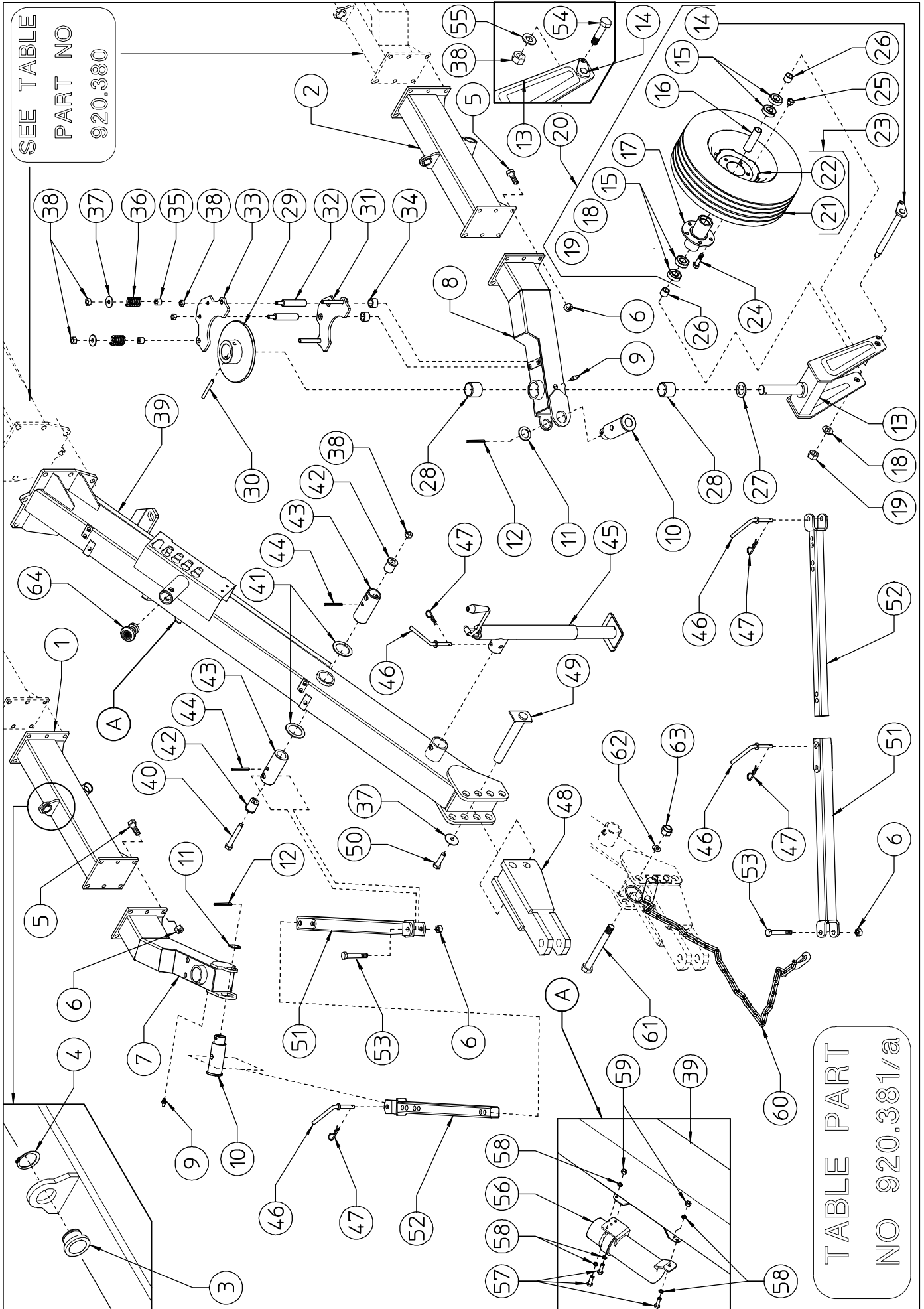

TABLE PART NO 920.381/a - FRONT SECTIONS AND DRAWBAR (18-20 WHEELS)					
ITEM	Q.ty MKE/18	Q.ty MKE/20	SITREX PART NO	DESCRIPTION	NOTE
31	2	2	260.083	BRAKE COUNTERPLATE	
32	4	4	260.092	PIN ø20-M12	
33	2	2	260.082	BRAKE PLATE	
34	4	4	260.091	SHIM ø21-30x10	
35	4	4	250.259	SPACER	
36	4	4	200.044	SPRING ø5-ø30x45	
37	6	6	600.845	WASHER ø12-36x4	
38	11	11	600.077	NUT M12 DIN 980	
39	1	1	250.237	FRONT DRAWBAR	
40	1	1	610.516	SCREW M12x100 DIN 931 8.8	
41	2	2	250.126	SHIM ø50,5-70x3	
42	2	2	250.269	BUSHING	
43	2	2	250.270	BUSHING	
44	2	2	600.447	SPRING PIN ø8x70 DIN 1481 PLATED	
45	1	1	220.166	PARKING STAND	
46	5	5	200.222	PIN ø15	
47	5	5	600.019	HAIRPIN ø3	
48	1	1	250.271	TRACTOR HITCH	
49	2	2	200.828	PIN ø25	
50	2	2	600.770	SCREW M12x20 DIN 933 8.8	
51	2	2	250.272	OUTER ARM	
52	2	2	250.273	INNER ARM	
53	2	2	610.872	SCREW M16x90 DIN 931 8.8	
54	2	2	600.616	SCREW M12x35 DIN 933 8.8	
55	2	2	600.089	WASHER ø13 DIN 125A	
56	1	1	230.457	CANISTER	
57	3	3	630.003	SCREW M6x20 DIN 933 8.8	
58	6	6	600.135	WASHER ø6,6-18x2	
59	3	3	600.472	NUT M6 DIN 980	
60	1	1	220.500	SAFETY CHAIN	
61	1	1	620.019	SCREW M22x150 DIN 931 8.8	
62	1	1	600.214	SPRING WASHER ø23 similar to DIN 127 B	
63	1	1	600.200	NUT M22 DIN 934	
64	1	1	610.790	PLUG	

TABLE
PART NO
920.382

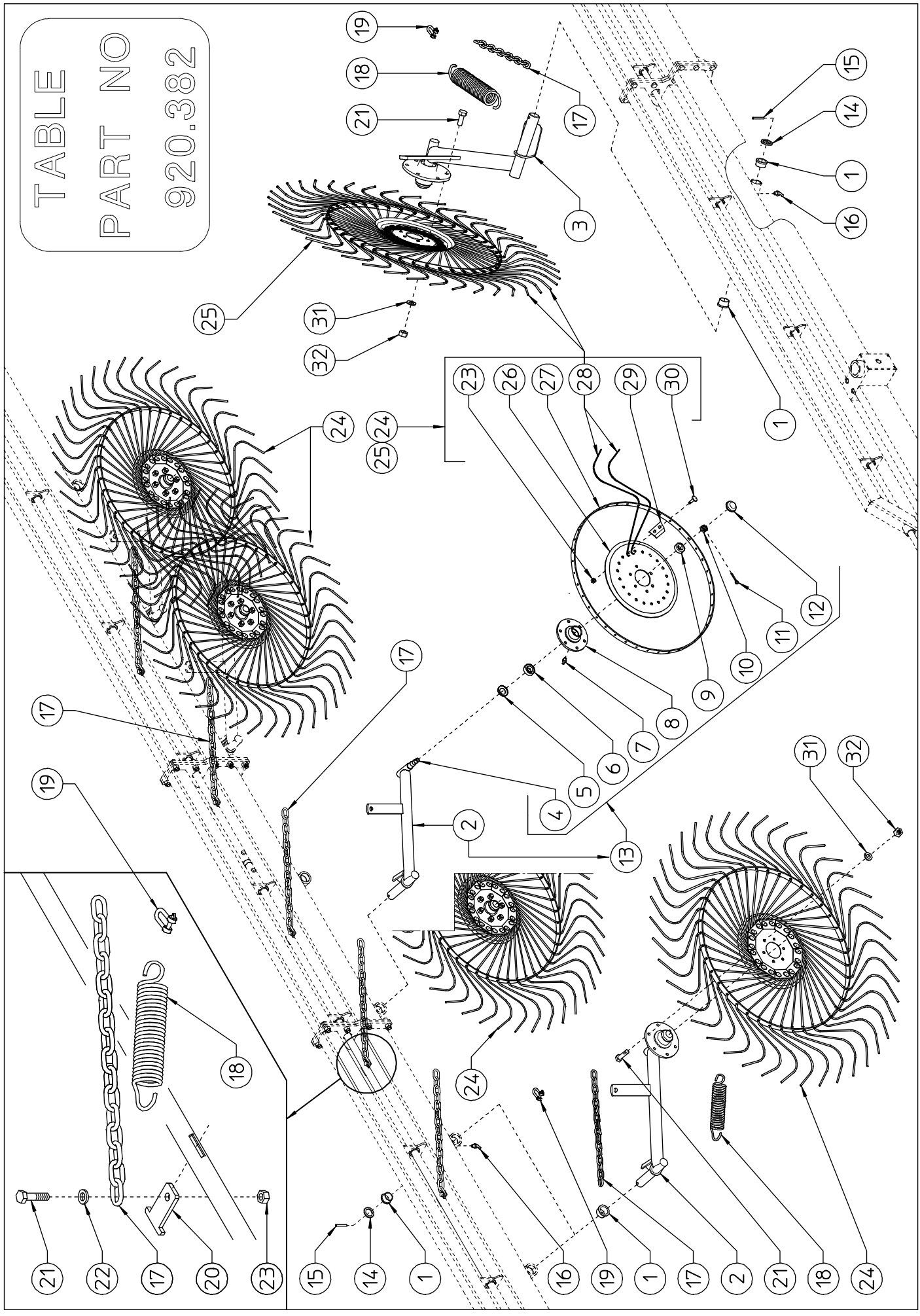
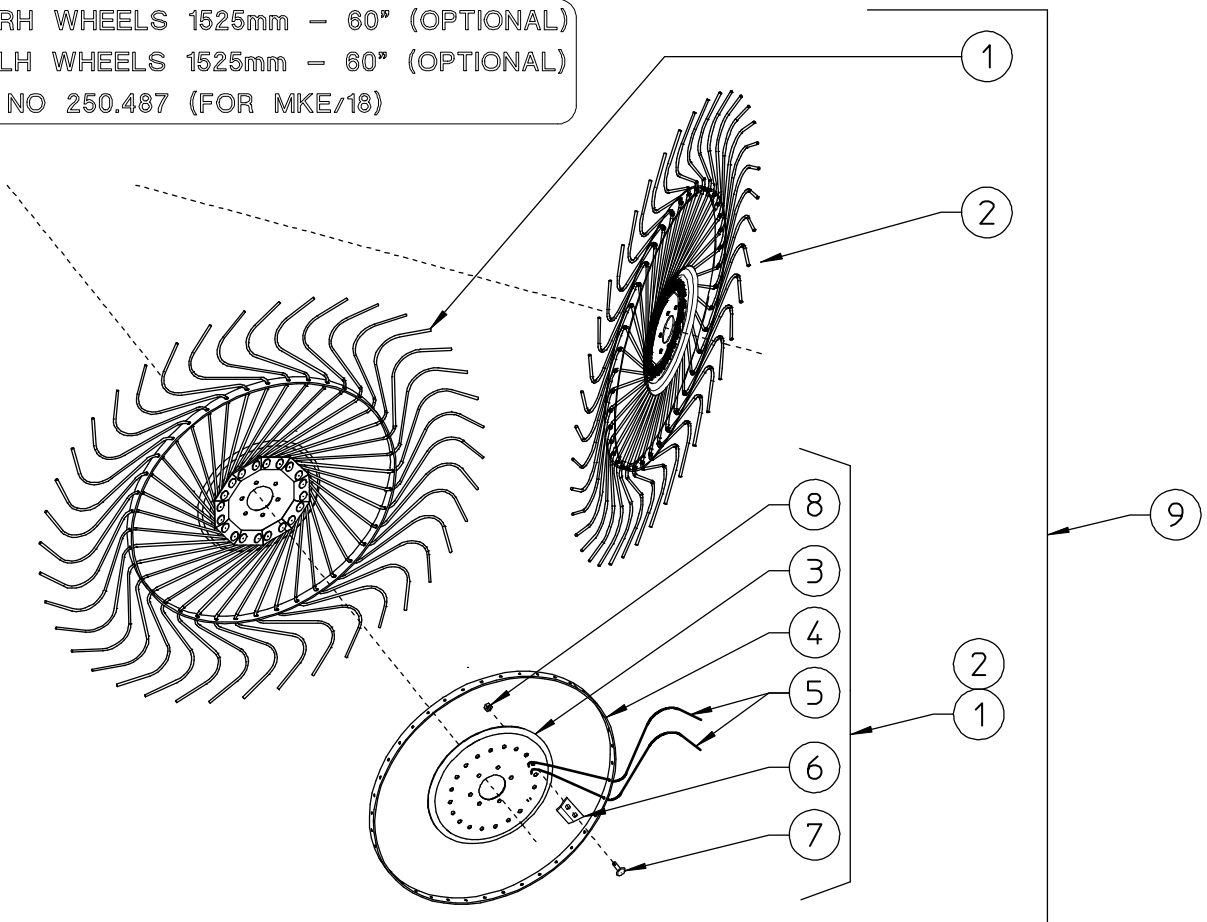

TABLE PART NO 920.382 - ARMS, WHEELS 55" AND ACCESORIES (18-20 WHEELS)

ITEM	Q.ty MKE/18	Q.ty MKE/20	SITREX PART NO	DESCRIPTION	NOTE
1	36	40	200.029	BUSHING	
2	9	10	250.280	RH ARMS	
3	9	10	250.281	LH ARMS	
4	18	20	205.277	PIN	
5	18	20	600.011	DUST COVER	
6	18	20	600.012	BEARING 30205	
7	18	20	600.034	GREASE NIPPLE M8	
8	18	20	600.013	HUB	
9	18	20	600.014	BEARING 30204	
10	18	20	600.015	SLOTTED NUT M18x1,5	
11	18	20	600.301	SPLIT PIN ø3x30 DIN 94	
12	18	20	600.016	CAP	
13	18	20	205.041	HUB ASSY	
14	18	20	200.028	WASHER ø35-50x5	
15	18	20	600.027	SPLIT PIN ø8x50 DIN 1481	
16	18	20	600.968	GREASE NIPPLE M6x45°	
17	18	20	250.282	CHaine	
18	18	20	200.046	SPRING	
19	18	20	610.317	"D" SACKLES	
20	18	20	250.283	SUPPORT	
21	126	140	600.006	SCREW M10x25 DIN 933 8.8	
22	18	20	620.250	WASHER ø11-30x2,5 UNI 6593	
23	378	420	600.029	NUT M10 DIN 980	
24	9	10	210.180	RH FINGER WHEEL	
25	9	10	210.181	LH FINGER WHEEL	
26	18	20	200.010	FLANGE	
27	18	20	200.009	RIM	
28	720	800	210.621	TINE ø7	
29	180	200	200.012	TINE CLAMP	
30	360	400	600.005	SCREW M10x25 DIN 603	
31	108	120	600.024	SPRING WASHER ø10,5 DIN 127B	
32	108	120	600.010	NUT M10 DIN 934	

N° 9 RH WHEELS 1525mm - 60" (OPTIONAL)
 N° 9 LH WHEELS 1525mm - 60" (OPTIONAL)
 PART NO 250.487 (FOR MKE/18)



N°10 RH WHEELS 1525mm - 60" (OPTIONAL)
 N°10 LH WHEELS 1525mm - 60" (OPTIONAL)
 PART NO 250.488 (FOR MKE/20)

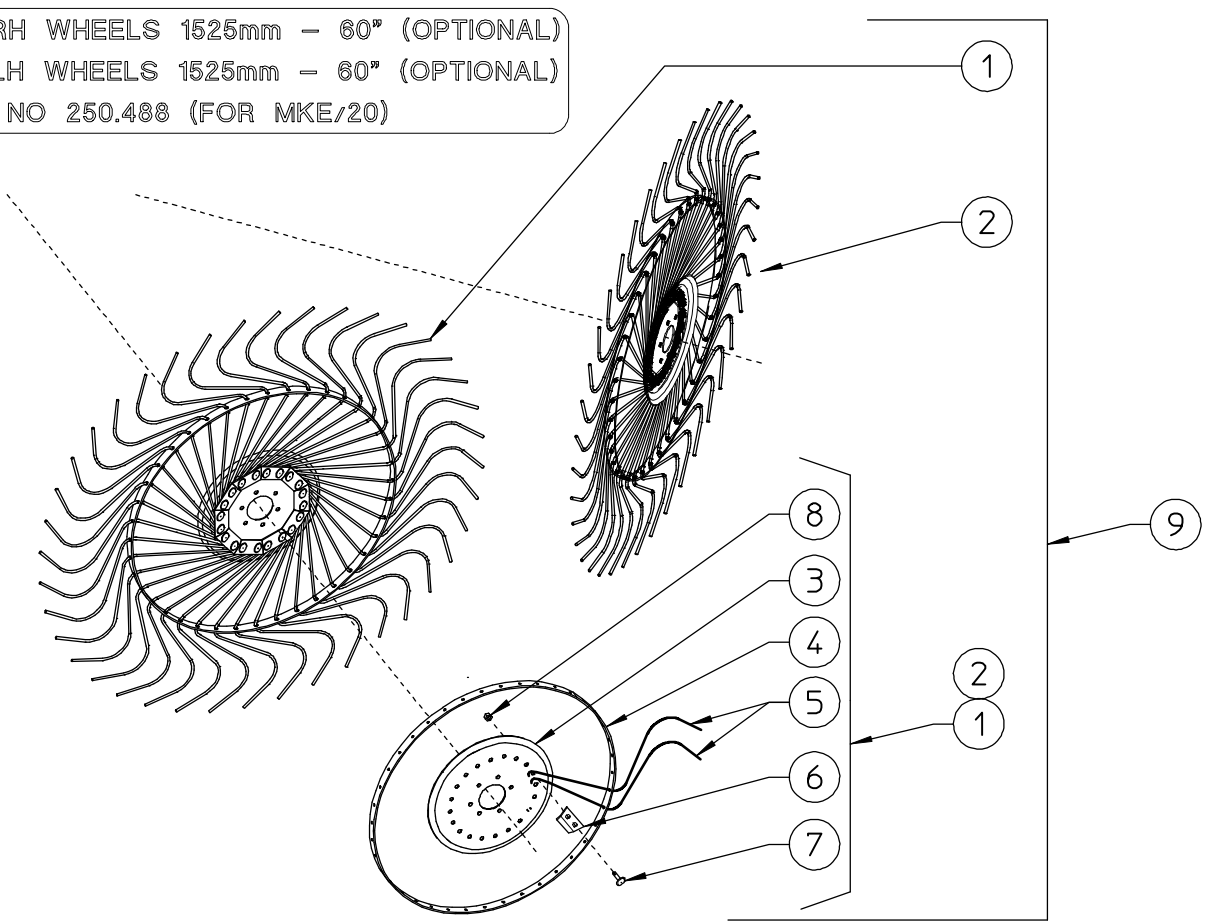

RAKE WHEELS 1525mm - 60" OPTIONAL KIT FOR MKE/18			
ITEM	Q.ty	PART NO	DESCRIPTION
1	9	230.279	RH FINGER WHEEL 60"
2	9	230.280	LH FINGER WHEEL 60"
3	18	230.338	FLANGE
4	18	230.326	RIM
5	750	230.327	TINE \varnothing 7,5
6	180	200.012	TINE CLAMP
7	360	600.005	SCREW M10x25 DIN 603
8	360	600.029	NUT M10 DIN 980
9	1	250.487	RAKE WHEELS KIT 60" FOR MKE/18 OPTIONAL

RAKE WHEELS 1525mm - 60" OPTIONAL KIT FOR MKE/20			
ITEM	Q.ty	PART NO	DESCRIPTION
1	10	230.279	RH FINGER WHEEL 60"
2	10	230.280	LH FINGER WHEEL 60"
3	20	230.338	FLANGE
4	20	230.326	RIM
5	800	230.327	TINE \varnothing 7,5
6	200	200.012	TINE CLAMP
7	400	600.005	SCREW M10x25 DIN 603
8	400	600.029	NUT M10 DIN 980
9	1	250.488	RAKE WHEELS KIT 60" FOR MKE/20 OPTIONAL

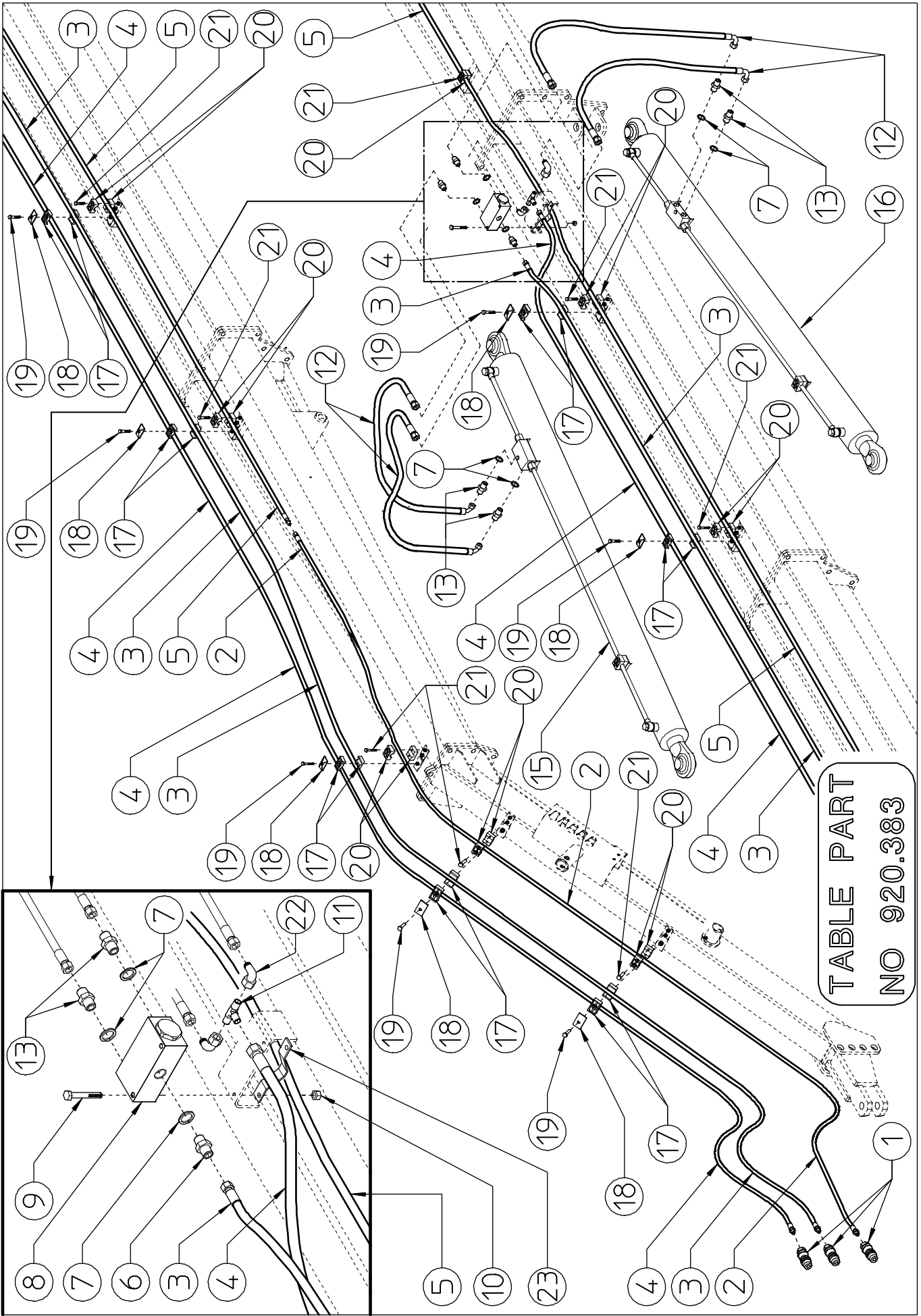

TABLE PART NO 920.383 - FRONT HYDRAULIC COMPONENTS (18-20 WHEELS)					
ITEM	Q.ty MK18	Q.ty MK20	SITREX PART NO	DESCRIPTION	NOTE
1	3	3	620.329	RAPID COUPLINGS 1/2" NPTM	
2	1	1	640.032	HOSE 3/8" L.4550-179,13" 1/2" NPTF- M JIC 3/4"	
3	1	1	640.099	HOSE 1/2" L.9450-372,05" 1/2" NPTF- F JIC 7/8"	
4	1	1	640.100	HOSE 1/2" L.9550-376" 1/2" NPTF- F JIC 3/4"	
5	1	1	640.101	HOSE 3/8" L.8400-330,71" M JIC 3/4" - F JIC 3/4"	
6	1	1	640.034	NIPPLE JIC 7/8" - 3/8" GAS	
7	7	7	620.452	WASHER ø3/8" BONDED	
8	1	1	600.974	FLOW DIVIDER 3/8"	
9	2	2	600.970	SCREW M6x60 DIN 931	
10	2	2	600.472	NUT M6 DIN 980	
11	1	1	640.036	"T" FITTING - MALE JIC 3/4"	
12	4	4	640.038	HOSE 3/8" L.750-29,53" F JIC 3/4" - F90° JIC 3/4"	
13	6	6	640.035	NIPPLE 3/8" GAS - JIC 3/4"	
14	DELETED				
15	1	1	250.286	RH CYLINDER ø80-50 WITH VALVE	
16	1	1	250.287	LH CYLINDER ø80-50 WITH VALVE	
17	14	14	610.041	DOUBLE HOSE COLLAR ø22-22	
18	7	7	610.043	LOCK	
19	7	7	610.044	SCREW M8x45 DIN 933	
20	16	16	610.035	HOSE COLLAR ø18	
21	16	16	610.037	SCREW M6x25 DIN 912	
22	2	2	640.057	FITTING 90° M3/4" JIC - F3/4" JIC	
23	1	1	250.366	HOSE SUPPORT	

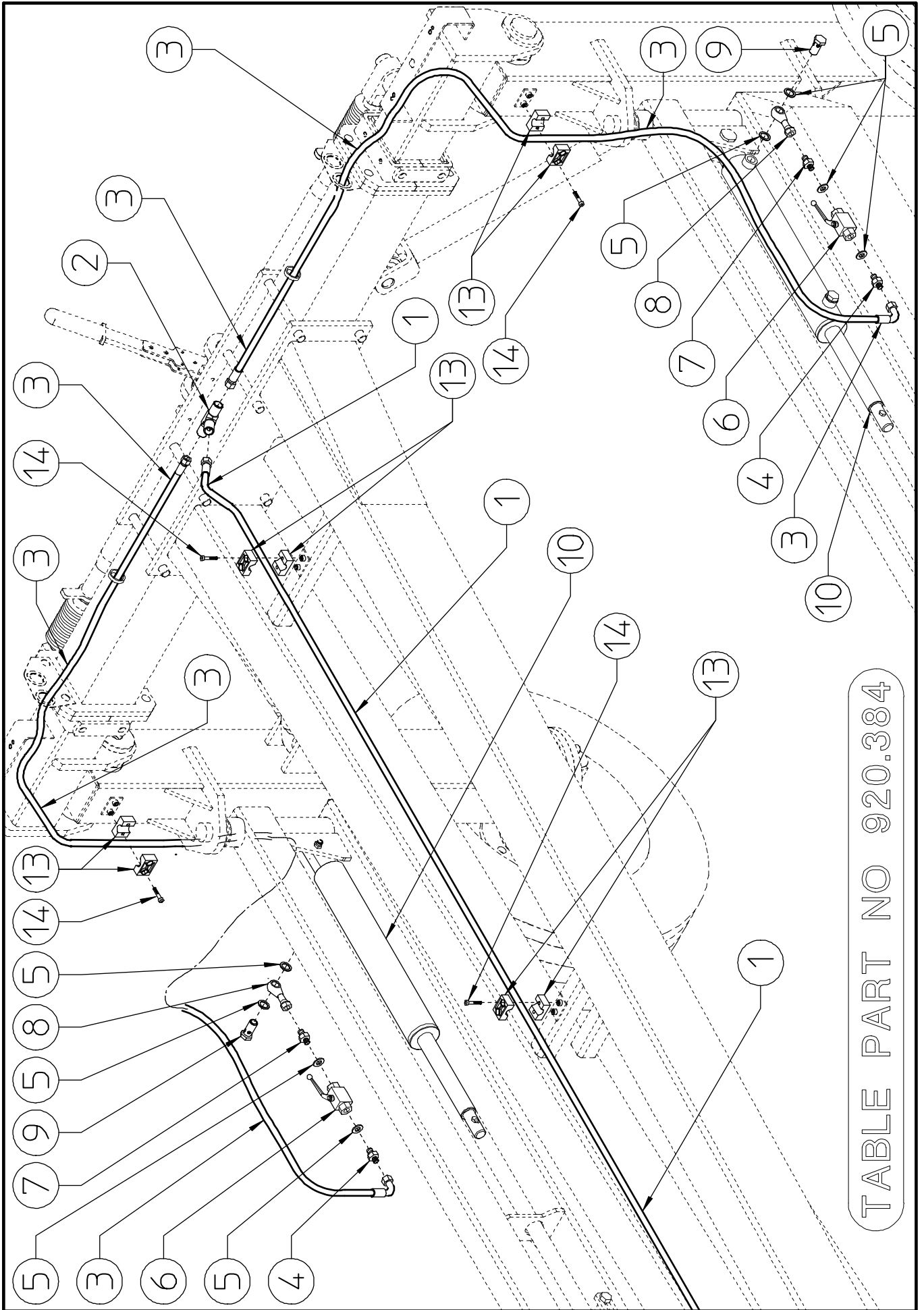

TABLE PART NO 920.384

TABLE PART NO 920.384 - REAR HYDRAULIC COMPONENTS (18-20 WHEELS)					
ITEM	Q.ty MK18	Q.ty MK20	SITREX PART NO	DESCRIPTION	NOTE
1	1	1	640.101	HOSE 3/8" L.8400-330,71" M JIC 3/4" - F JIC 3/4"	
2	1	1	640.036	"T" FITTING - MALE JIC 3/4"	
3	2	2	640.063	HOSE 3/8" L.1840-72,44" F JIC 3/4" F JIC 3/4"	
4	2	2	640.035	NIPPLE 3/8" GAS - JIC 3/4"	
5	8	8	620.452	WASHER ø3/8" BONDED	
6	2	2	610.002	VALVE 3/8"	
7	2	2	600.270	NIPPLE 3/8" GAS - 3/8"GAS	
8	2	2	630.315	FITTING BANJO 3/8"	
9	2	2	600.040	SCREW 3/8"	
10	2	2	250.238	CYLINDER ø50-30	
11				DELETED	
12				DELETED	
13	8	8	610.035	HOSE COLLAR ø18	
14	8	8	610.037	SCREW M6x25 DIN 912	

TABLE PART NO 920.363

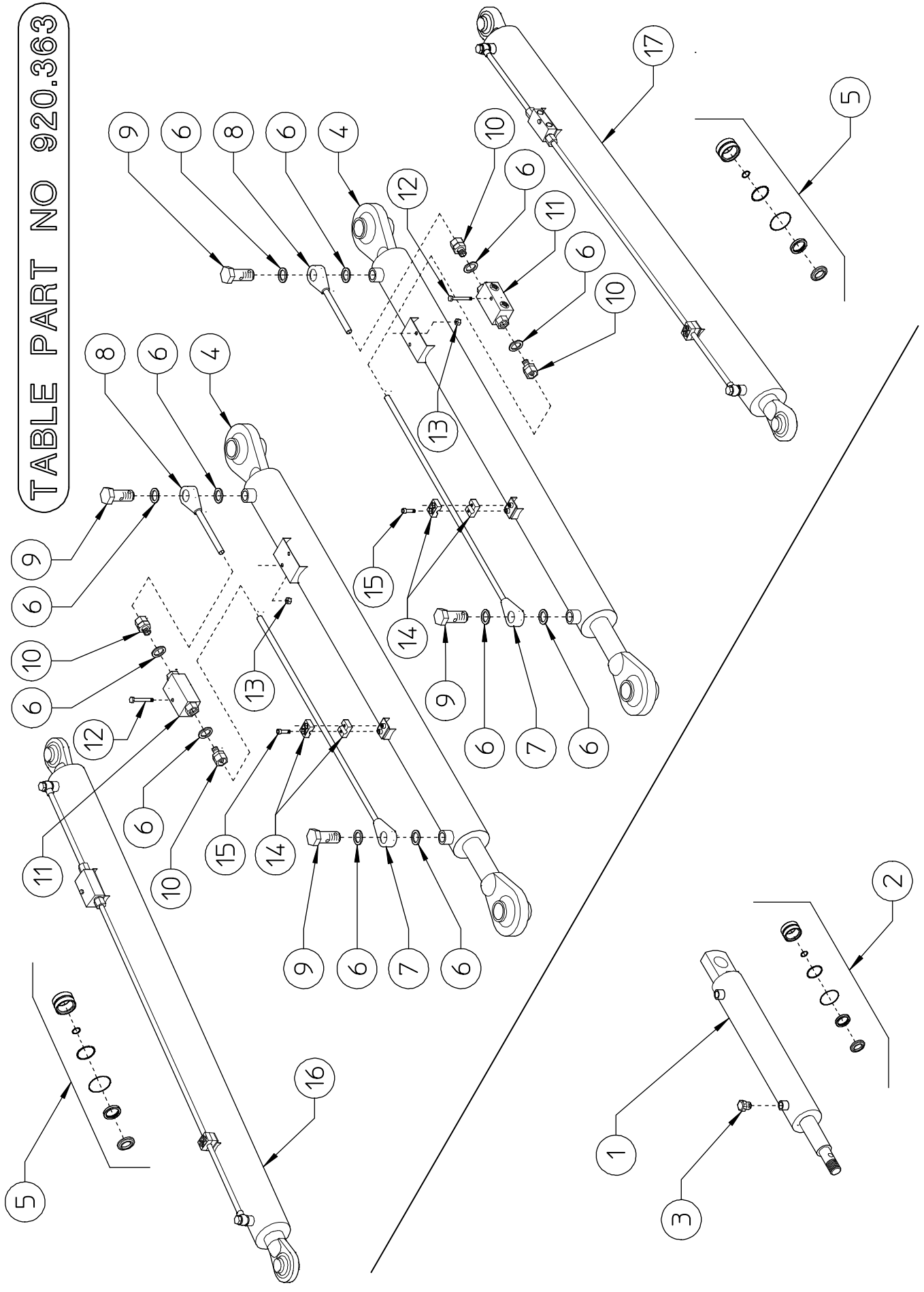
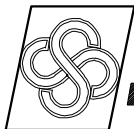

TABLE PART NO 920.363 - CYLINDER WITH VALVE AND ACCESORIES (14-16-18-20 WHEELS)							
ITEM	Q.ty MK14	Q.ty MK16	Q.ty MK18	Q.ty MK20	SITREX PART NO	DESCRIPTION	NOTE
1	2	2	2	2	250.238	CYLINDER ø50-30	
2	2	2	2	2	640.027	SET OF GASKET ø50-30	
3	2	2	2	2	620.012	PLUG 3/8"	
4	2	2	2	2	250.239	CYLINDER ø80-50	
5	2	2	2	2	640.984	SET OF GASKET ø80-50	
6	12	12	12	12	620.452	WASHER ø3/8" BONDED	
7	2	2	2	2	210.240	TUBE ø12 L.1500-59"	
8	2	2	2	2	210.194	TUBE ø12 L.200-7,87"	
9	4	4	4	4	600.040	SCREW ø3/8"	
10	4	4	4	4	610.469	FITTING 3/8"-ø12	
11	2	2	2	2	600.799	LOCK VALVE 3/8"	
12	2	2	2	2	600.869	SCREW M6x40 DIN 931	
13	2	2	2	2	600.472	NUT M6 DIN 980	
14	4	4	4	4	610.423	HOSE COLLAR ø12	
15	4	4	4	4	610.424	SCREW M6x20 DIN 912	
16	1	1	1	1	250.286	RH CYLINDER ø80-50 WITH VALVE	
17	1	1	1	1	250.287	LH CYLINDER ø80-50 WITH VALVE	



sitrex[®] SpA
AGRICULTURAL MACHINERY

Zona Industriale-Viale Grecia, 8
06018 TRESTINA-(Perugia)-ITALY
Tel. +39.075.8540021-Telefax +39.075.8540523
e-mail: sitrex@sitrex.it www.sitrex.com

