

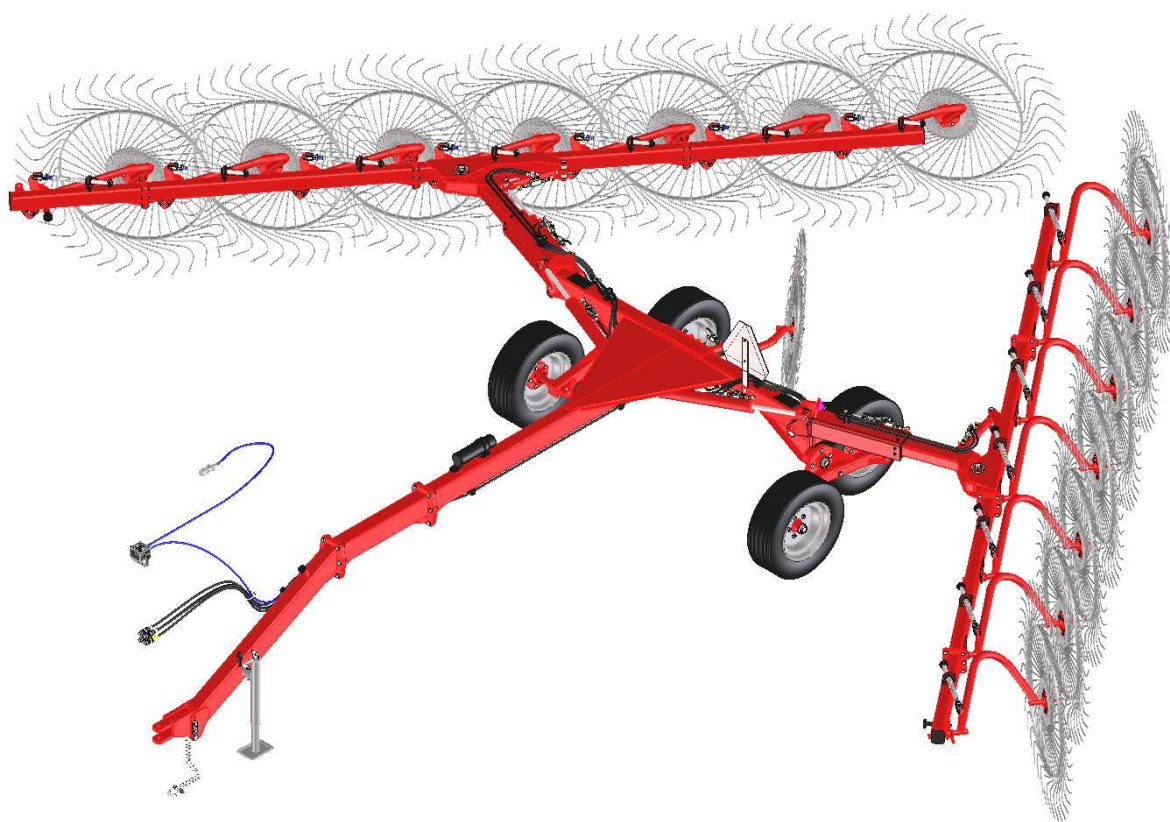

AGRICULTURAL MACHINERY

sitrex®
Spa

SPARE PARTS LIST



QRX 12/14

SECTION 1 SPARE PARTS LIST

Order spare parts with the serial number of the machine.

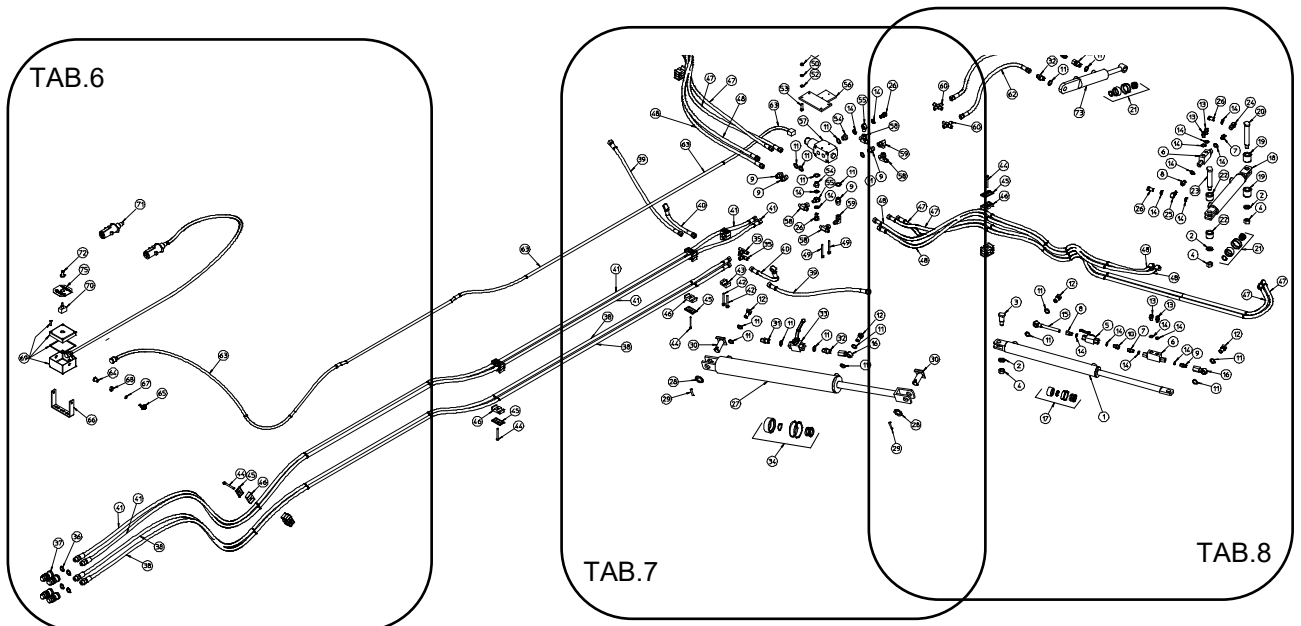
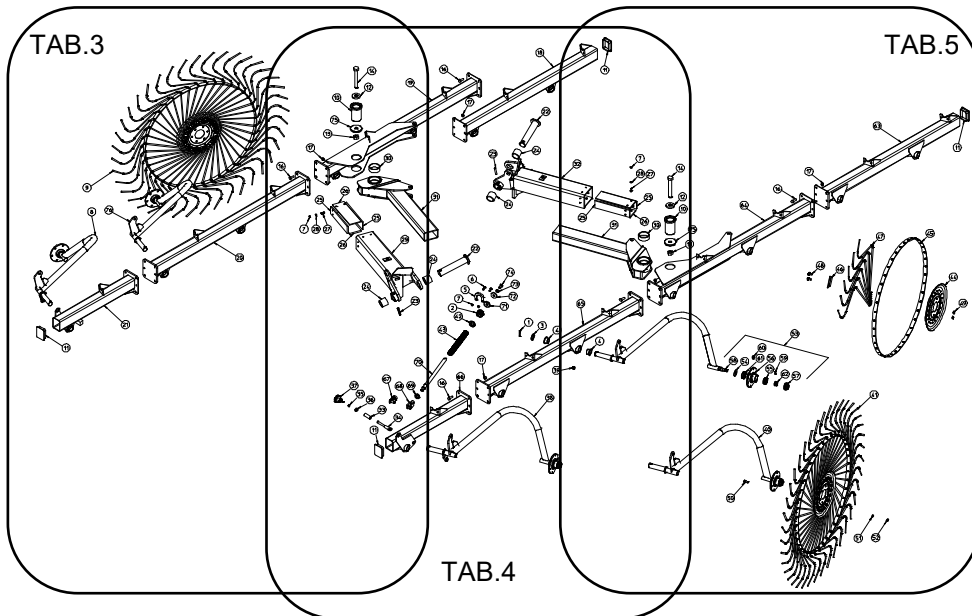
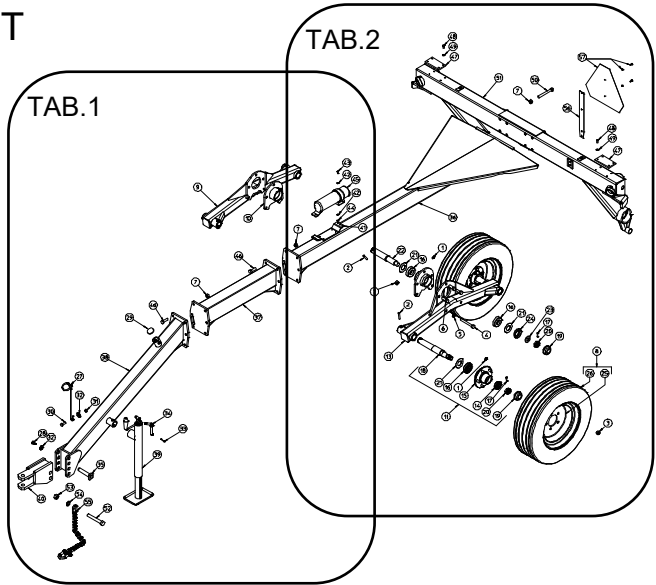

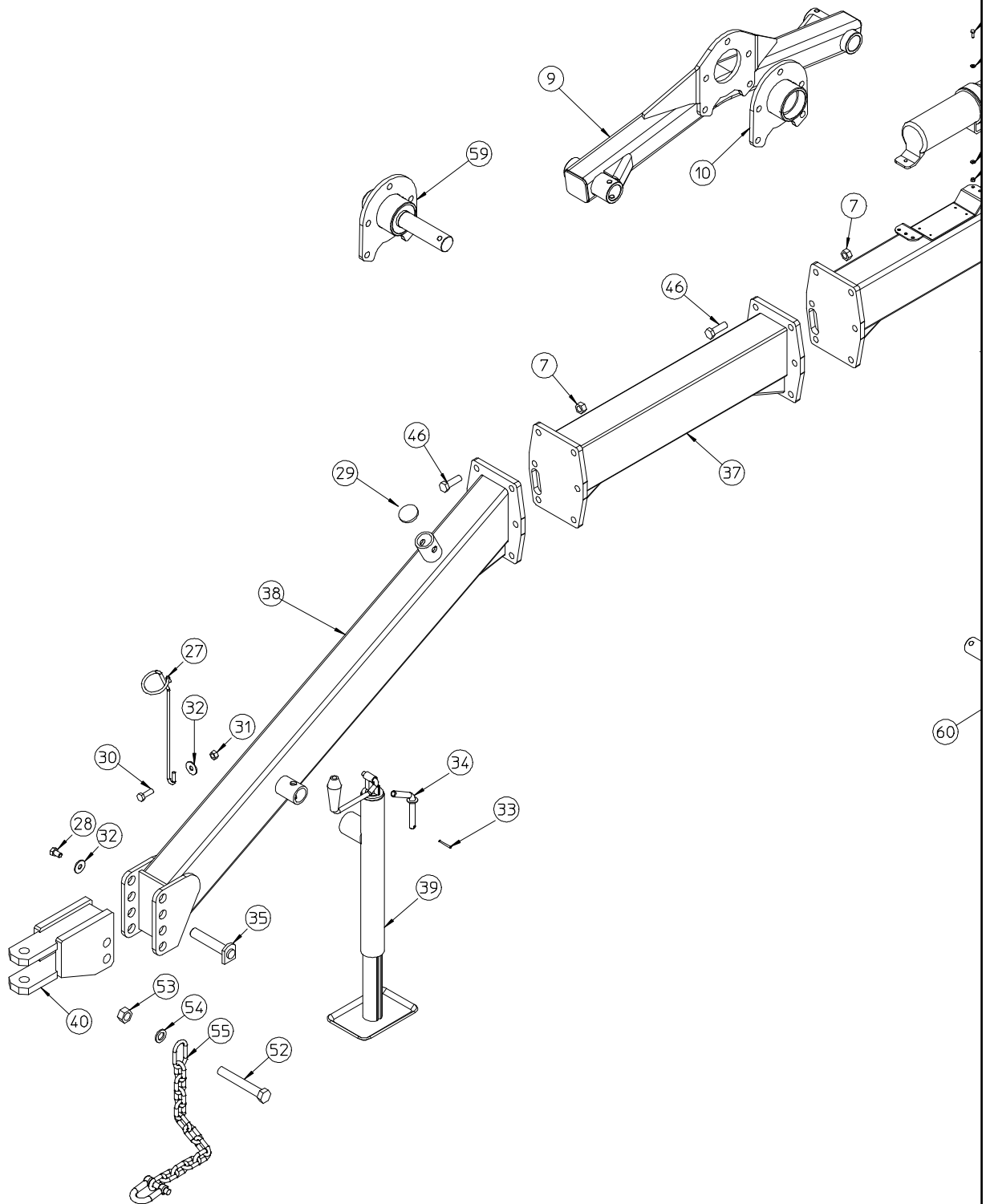

TABLE 920.401 FRAME

Pos.	Part No.	Description	Pos.	Part No.	Description
1	600.034	GREASE NIPPLE M8	31	600.077	NUT M12 DIN 980
2	600.826	SCREW M12x75 DIN 931 8.8	32	600.092	WASHER ϕ 12x36
3	600.289	NUT M16x1,5	33	600.019	SPLIT PIN ϕ 3
4	610.698	SCREW M16x130 DIN 931 8.8	34	200.222	PIN
5	600.741	WASHER ϕ 17 UNI 6592	35	200.828	PIN
6	610.167	SCREW M16x45 DIN 933 8.8	36	250.717	DRAWBAR
7	600.080	NUT M16 DIN 980	37	250.718	DRAWBAR (QRX14 only)
8	600.281	TIRE ASSY	38	260.839	DRAWBAR
9	250.710	TANDEM AXLE RH	39	220.166	PARKING STAND
10	250.711	TANDEM HUB RH	40	250.271	TRACTOR HITCH
11	230.431	HUB ASSY	41	225.195	CANISTER SUPPORT PLATE
12	250.716	TANDEM HUB LH	42	600.135	WASHER ϕ 6,6-18x2 UNI 6593
13	250.715	TANDEM AXLE LH	43	630.003	SCREW M6x20 DIN 933
14	600.287	BEARING 30206	44	600.472	NUT M6 DIN 980
15	600.286	HUB	45	230.457	CANISTER
16	600.285	BEARING 30208	46	600.176	SCREW M16x50 DIN 931 8.8
17	600.291	SPLIT PIN ϕ 4x40 DIN 94 3.6	47	230.506	BLOCK
18	225.839	HUB PIN	48	600.223	SCREW M8x20 DIN 933 8.8
19	600.290	CAP	49	610.185	WASHER ϕ 9-21x2 UNI 6593
20	600.288	LOCKING NUT M27x1,5	50	600.595	SCREW M16x140 DIN 931 8.8
21	600.284	DUST COVER	51	250.721	FRAME
22	250.714	PIN	52	620.019	SCREW M22x150 DIN 931 8.8
23	250.713	WASHER	53	600.200	NUT M22 DIN 934
24	250.712	SPACER	54	600.214	SPRING WASHER ϕ 23 DIN 125A
25	600.304	RIM	55	220.500	SAFETY CHAIN
26	600.303	TIRE	56	220.413	PANEL SUPPORT (USA HighWay Code)
27	110.105	SUPPORT	57	220.414	TRANSPORT PANEL (USA HighWay Code)
28	600.770	SCREW M12x20 DIN 933 8.8	58	600.896	PLUG
29	610.790	PLUG	59	260.118	TANDEM HUB ASSY RH
30	600.616	SCREW M12x35 DIN 933 8.8	60	260.119	TANDEM HUB ASSY LH

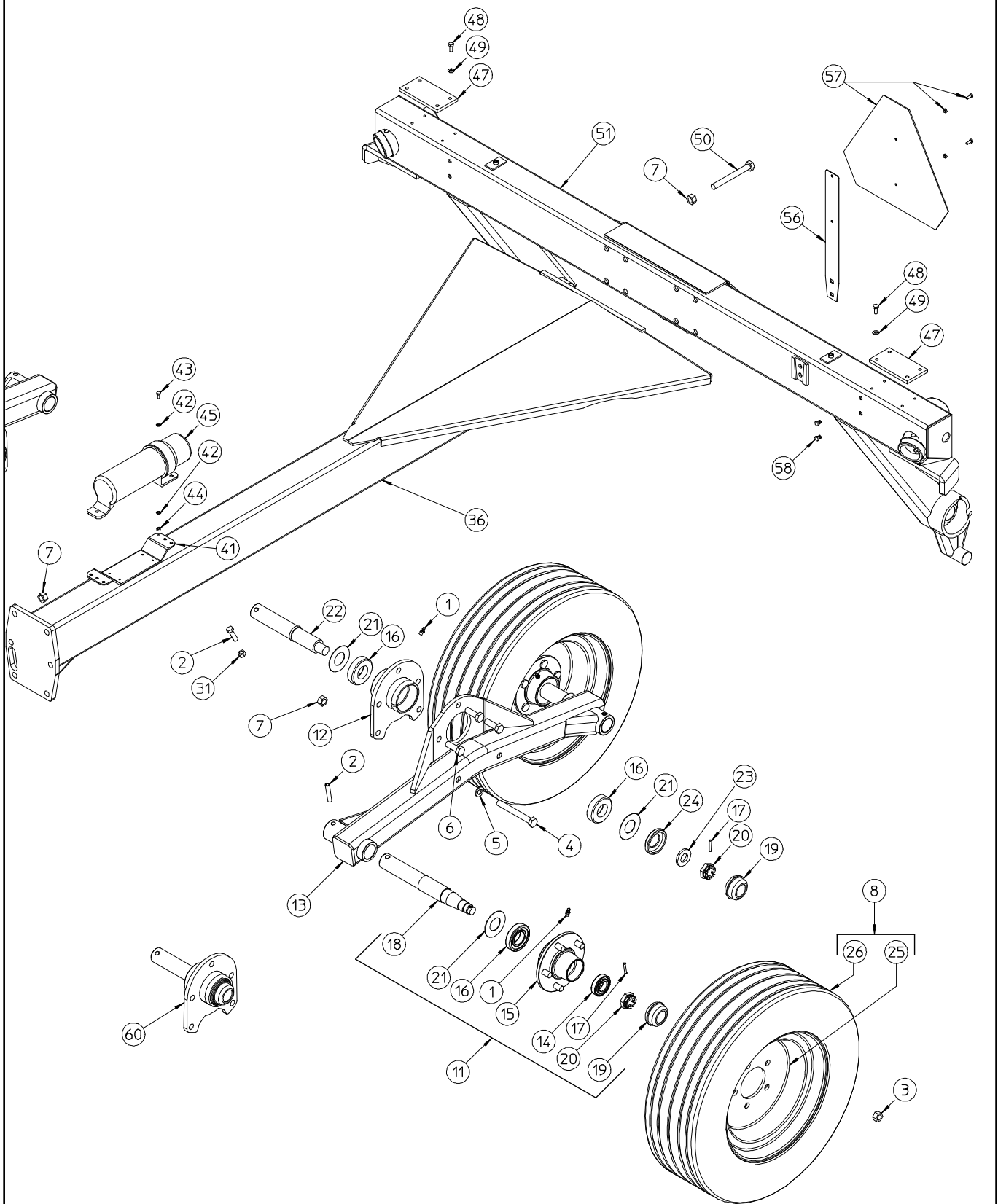

TABLE 920.401 FRAME

Pos.	Part No.	Description	Pos.	Part No.	Description
1	600.034	GREASE NIPPLE M8	31	600.077	NUT M12 DIN 980
2	600.826	SCREW M12x75 DIN 931 8.8	32	600.092	WASHER ϕ 12x36
3	600.289	NUT M16x1,5	33	600.019	SPLIT PIN ϕ 3
4	610.698	SCREW M16x130 DIN 931 8.8	34	200.222	PIN
5	600.741	WASHER ϕ 17 UNI 6592	35	200.828	PIN
6	610.167	SCREW M16x45 DIN 933 8.8	36	250.717	DRAWBAR
7	600.080	NUT M16 DIN 980	37	250.718	DRAWBAR (QRX14 only)
8	600.281	TIRE ASSY	38	260.839	DRAWBAR
9	250.710	TANDEM AXLE RH	39	220.166	PARKING STAND
10	250.711	TANDEM HUB RH	40	250.271	TRACTOR HITCH
11	230.431	HUB ASSY	41	225.195	CANISTER SUPPORT PLATE
12	250.716	TANDEM HUB LH	42	600.135	WASHER ϕ 6,6-18x2 UNI 6593
13	250.715	TANDEM AXLE LH	43	630.003	SCREW M6x20 DIN 933
14	600.287	BEARING 30206	44	600.472	NUT M6 DIN 980
15	600.286	HUB	45	230.457	CANISTER
16	600.285	BEARING 30208	46	600.176	SCREW M16x50 DIN 931 8.8
17	600.291	SPLIT PIN ϕ 4x40 DIN 94 3.6	47	230.506	BLOCK
18	225.839	HUB PIN	48	600.223	SCREW M8x20 DIN 933 8.8
19	600.290	CAP	49	610.185	WASHER ϕ 9-21x2 UNI 6593
20	600.288	LOCKING NUT M27x1,5	50	600.595	SCREW M16x140 DIN 931 8.8
21	600.284	DUST COVER	51	250.721	FRAME
22	250.714	PIN	52	620.019	SCREW M22x150 DIN 931 8.8
23	250.713	WASHER	53	600.200	NUT M22 DIN 934
24	250.712	SPACER	54	600.214	SPRING WASHER ϕ 23 DIN 125A
25	600.304	RIM	55	220.500	SAFETY CHAIN
26	600.303	TIRE	56	220.413	PANEL SUPPORT (USA HighWay Code)
27	110.105	SUPPORT	57	220.414	TRANSPORT PANEL (USA HighWay Code)
28	600.770	SCREW M12x20 DIN 933 8.8	58	600.896	PLUG
29	610.790	PLUG	59	260.118	TANDEM HUB ASSY RH
30	600.616	SCREW M12x35 DIN 933 8.8	60	260.119	TANDEM HUB ASSY LH

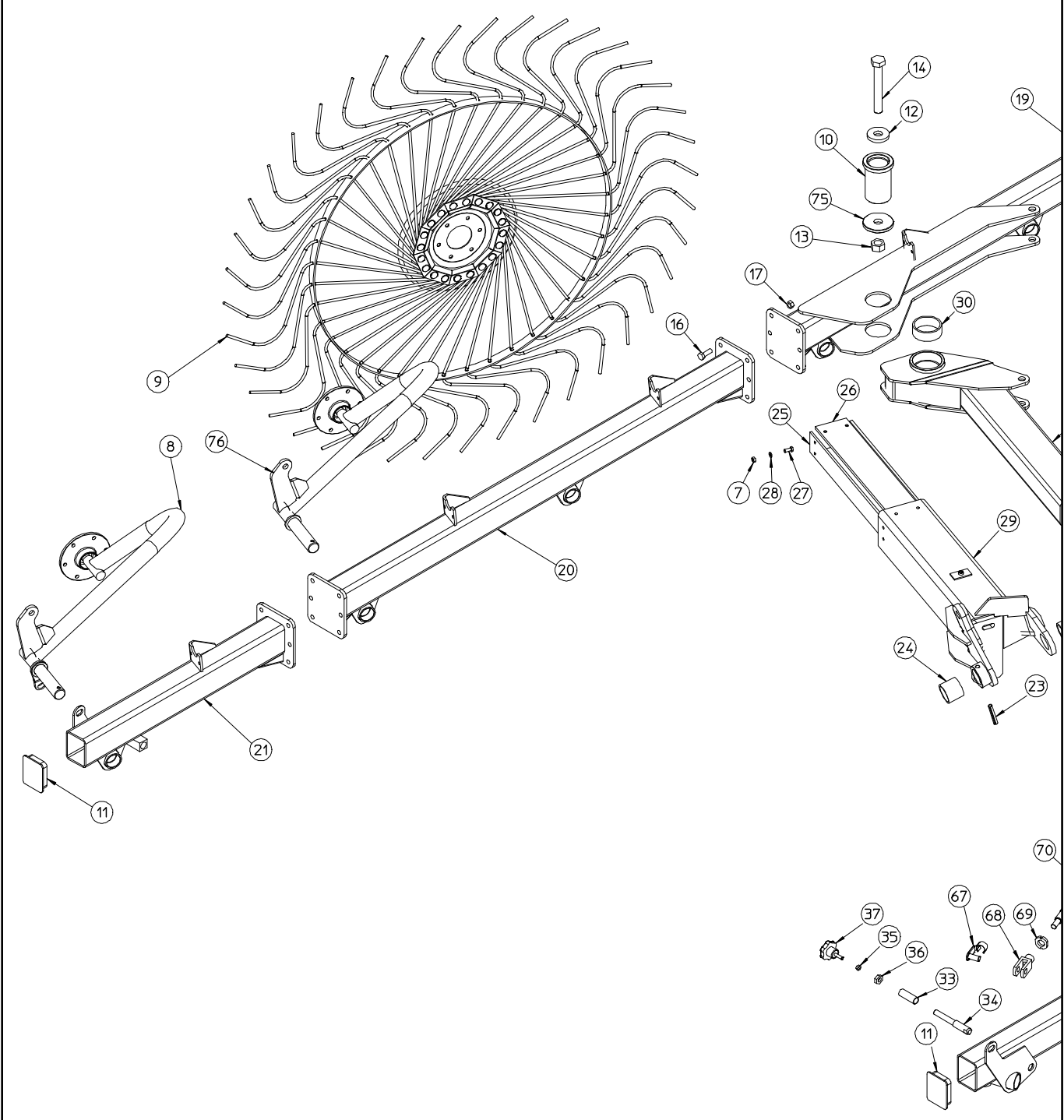

TABLE 920.402 RAKE ARMS

Pos.	Part No.	Description	Pos.	Part No.	Description
1	600.027	SPRING PIN ø8x50	41	210.181	WHEEL ASSY 55", LH (ø7mm)
2	230.659	BUSH		230.280	WHEEL ASSY 60", LH (OPTIONAL)
3	200.028	WASHER ø35,5-50x5	42	230.661	WASHER ø26-55x5
4	200.029	BUSH	43	230.965	SPRING ø4mm
5	230.664	SUPPORT	44	200.010	FLANGE, WHEEL 55"
6	600.702	SCREW M8x25 DIN 933 8.8		230.338	FLANGE, WHEEL 60" (OPTIONAL)
7	600.076	NUT M8 DIN 980	45	200.009	RIM, WHEEL 55"
8	260.147	WHEEL ARM SPECIAL, RH		230.326	RIM, WHEEL 60" (OPTIONAL)
9	210.180	WHEEL ASSY 55", RH (ø7mm)	46	200.012	TINE CLAMP
	230.279	WHEEL ASSY 60", RH (OPTIONAL)	47	210.621	TINE ø0,276" (7mm), WHEEL 55"
10	250.699	PIN		230.327	TINE ø0,295" (7,5mm), WHEEL 60" (OPTIONAL)
11	640.108	PLUG	48	600.005	SCREW M10x25 DIN 603
12	230.668	WASHER ø25-64x10	49	600.029	NUT M10 DIN 980
13	620.255	NUT M24 DIN 980	50	600.006	SCREW M10x25 DIN 933 8.8
14	640.114	SCREW M24x170 DIN 931 8.8	51	600.024	SPRING WASHER ø10,5 DIN 125A
15	230.667	WASHER ø25-90x10	52	600.010	NUT M10 DIN 934
16	600.616	SCREW M12x35 DIN 933 8.8	53	205.041	HUB ASSY
17	600.077	NUT M12 DIN 980	54	600.011	DUST COVER
18	250.697	REAR SECTION, RH	55	600.014	BEARING 30204
19	250.696	CENTRAL SECTION, RH	56	600.013	WHEEL HUB
20	250.695	FRONT SECTION, RH	57	600.016	SAFETY CAP
21	250.698	EXTENSION SECTION, RH (QRX14 only)	58	205.277	PIN
22	230.319	PIN	59	600.301	SPLIT PIN ø3x30 DIN 94
23	600.656	SPRING PIN ø12x70 DIN 1481	60	600.034	GREASE NIPPLE M8
24	200.199	BUSH	61	600.012	BEARING 30205
25	250.725	NYLON PLATE	62	600.015	LOCKING NUT M18x1,5
26	250.727	NYLON PLATE	63	250.702	REAR SECTION, LH
27	630.136	SCREW M8x25 DIN 7991A	64	250.701	CENTRAL SECTION, LH
28	610.185	WASHER ø9-21x2 UNI 6593	65	250.700	FRONT SECTION, LH
29	250.728	ARM EXTERNAL, RH	66	250.703	EXTENSION SECTION, LH (QRX14 only)
30	230.666	BUSH	67	630.586	PIN
31	250.730	ARM INTERNAL	68	630.375	FORK M16
32	250.729	ARM EXTERNAL, LH	69	230.729	NUT M22
33	230.716	SPRING	70	230.658	ROD
34	230.712	PIN	71	230.662	WASHER ø23-50x8
35	600.037	NUT M8 DIN 934	72	230.709	WASHER ø13-50x4
36	600.082	NUT M16 DIN 936	73	600.018	SPRING WASHER ø13 DIN 125A
37	630.571	KNOB	74	600.441	SCREW M12x25 DIN 933 8.8
38	260.148	WHEEL ARM SPECIAL, LH	75	230.667	WASHER ø25-90x10
39	600.124	GREASE NIPPLE M6	76	260.135	WHEEL ARM, RH
40	260.136	WHEEL ARM, LH	77	260.070	SHIM PLATE 1.5mm (0,059")
			77	260.073	SHIM PLATE 1mm (0,039")
			78	640.259	SCREW M8x30 DIN 7991A
			80	260.864	WASHER ø26-50x10

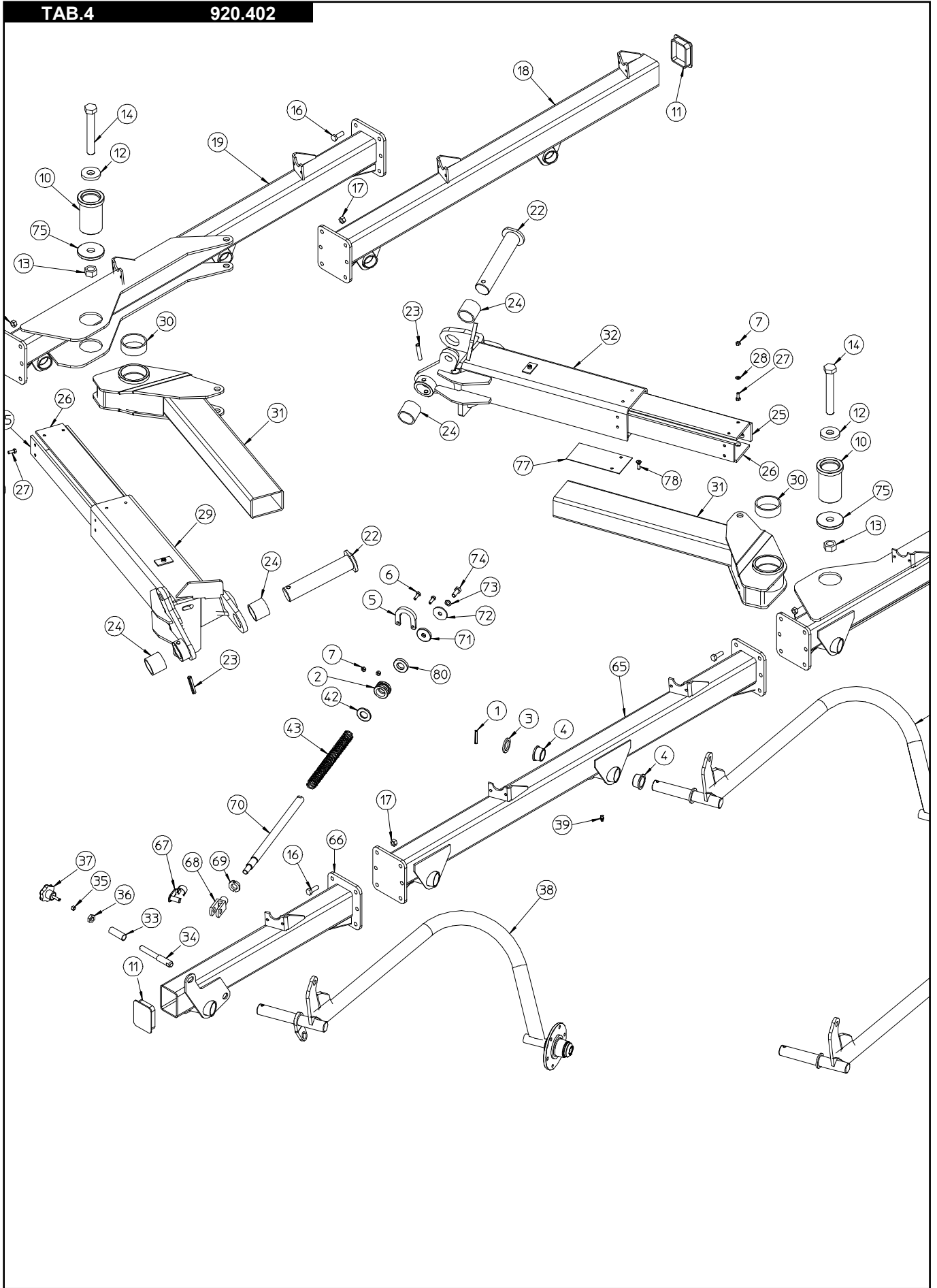

TABLE 920.402 RAKE ARMS

Pos.	Part No.	Description	Pos.	Part No.	Description
1	600.027	SPRING PIN ø8x50	41	210.181	WHEEL ASSY 55", LH (ø7mm)
2	230.659	BUSH		230.280	WHEEL ASSY 60", LH (OPTIONAL)
3	200.028	WASHER ø35,5-50x5	42	230.661	WASHER ø26-55x5
4	200.029	BUSH	43	230.965	SPRING ø4mm
5	230.664	SUPPORT	44	200.010	FLANGE, WHEEL 55"
6	600.702	SCREW M8x25 DIN 933 8.8		230.338	FLANGE, WHEEL 60" (OPTIONAL)
7	600.076	NUT M8 DIN 980	45	200.009	RIM, WHEEL 55"
8	260.147	WHEEL ARM SPECIAL, RH		230.326	RIM, WHEEL 60" (OPTIONAL)
9	210.180	WHEEL ASSY 55", RH (ø7mm)	46	200.012	TINE CLAMP
	230.279	WHEEL ASSY 60", RH (OPTIONAL)	47	210.621	TINE ø0,276" (7mm), WHEEL 55"
10	250.699	PIN		230.327	TINE ø0,295" (7,5mm), WHEEL 60" (OPTIONAL)
11	640.108	PLUG	48	600.005	SCREW M10x25 DIN 603
12	230.668	WASHER ø25-64x10	49	600.029	NUT M10 DIN 980
13	620.255	NUT M24 DIN 980	50	600.006	SCREW M10x25 DIN 933 8.8
14	640.114	SCREW M24x170 DIN 931 8.8	51	600.024	SPRING WASHER ø10,5 DIN 125A
15	230.667	WASHER ø25-90x10	52	600.010	NUT M10 DIN 934
16	600.616	SCREW M12x35 DIN 933 8.8	53	205.041	HUB ASSY
17	600.077	NUT M12 DIN 980	54	600.011	DUST COVER
18	250.697	REAR SECTION, RH	55	600.014	BEARING 30204
19	250.696	CENTRAL SECTION, RH	56	600.013	WHEEL HUB
20	250.695	FRONT SECTION, RH	57	600.016	SAFETY CAP
21	250.698	EXTENSION SECTION, RH (QRX14 only)	58	205.277	PIN
22	230.319	PIN	59	600.301	SPLIT PIN ø3x30 DIN 94
23	600.656	SPRING PIN ø12x70 DIN 1481	60	600.034	GREASE NIPPLE M8
24	200.199	BUSH	61	600.012	BEARING 30205
25	250.725	NYLON PLATE	62	600.015	LOCKING NUT M18x1,5
26	250.727	NYLON PLATE	63	250.702	REAR SECTION, LH
27	630.136	SCREW M8x25 DIN 7991A	64	250.701	CENTRAL SECTION, LH
28	610.185	WASHER ø9-21x2 UNI 6593	65	250.700	FRONT SECTION, LH
29	250.728	ARM EXTERNAL, RH	66	250.703	EXTENSION SECTION, LH (QRX14 only)
30	230.666	BUSH	67	630.586	PIN
31	250.730	ARM INTERNAL	68	630.375	FORK M16
32	250.729	ARM EXTERNAL, LH	69	230.729	NUT M22
33	230.716	SPRING	70	230.658	ROD
34	230.712	PIN	71	230.662	WASHER ø23-50x8
35	600.037	NUT M8 DIN 934	72	230.709	WASHER ø13-50x4
36	600.082	NUT M16 DIN 936	73	600.018	SPRING WASHER ø13 DIN 125A
37	630.571	KNOB	74	600.441	SCREW M12x25 DIN 933 8.8
38	260.148	WHEEL ARM SPECIAL, LH	75	230.667	WASHER ø25-90x10
39	600.124	GREASE NIPPLE M6	76	260.135	WHEEL ARM, RH
40	260.136	WHEEL ARM, LH	77	260.070	SHIM PLATE 1.5mm (0,059")
				260.073	SHIM PLATE 1mm (0,039")
			78	640.259	SCREW M8x30 DIN 7991A
			80	260.864	WASHER ø26-50x10

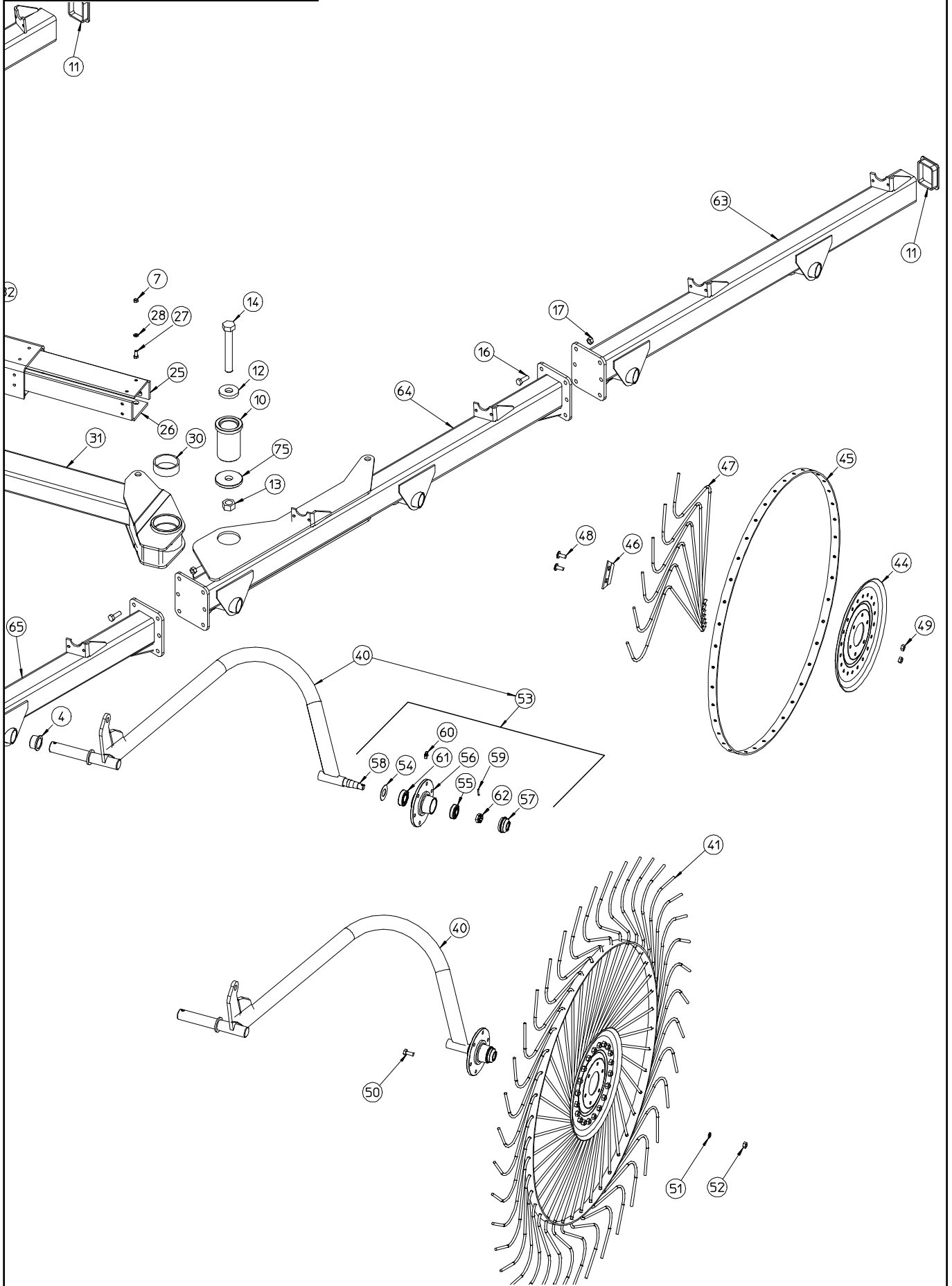

TABLE 920.402 RAKE ARMS

Pos.	Part No.	Description	Pos.	Part No.	Description
1	600.027	SPRING PIN ø8x50	41	210.181	WHEEL ASSY 55", LH (ø7mm)
2	230.659	BUSH		230.280	WHEEL ASSY 60", LH (OPTIONAL)
3	200.028	WASHER ø35,5-50x5	42	230.661	WASHER ø26-55x5
4	200.029	BUSH	43	230.965	SPRING ø4mm
5	230.664	SUPPORT	44	200.010	FLANGE, WHEEL 55"
6	600.702	SCREW M8x25 DIN 933 8.8		230.338	FLANGE, WHEEL 60" (OPTIONAL)
7	600.076	NUT M8 DIN 980	45	200.009	RIM, WHEEL 55"
8	260.147	WHEEL ARM SPECIAL, RH		230.326	RIM, WHEEL 60" (OPTIONAL)
9	210.180	WHEEL ASSY 55", RH (ø7mm)	46	200.012	TINE CLAMP
	230.279	WHEEL ASSY 60", RH (OPTIONAL)	47	210.621	TINE ø0,276" (7mm), WHEEL 55"
10	250.699	PIN		230.327	TINE ø0,295" (7,5mm), WHEEL 60" (OPTIONAL)
11	640.108	PLUG	48	600.005	SCREW M10x25 DIN 603
12	230.668	WASHER ø25-64x10	49	600.029	NUT M10 DIN 980
13	620.255	NUT M24 DIN 980	50	600.006	SCREW M10x25 DIN 933 8.8
14	640.114	SCREW M24x170 DIN 931 8.8	51	600.024	SPRING WASHER ø10,5 DIN 125A
15	230.667	WASHER ø25-90x10	52	600.010	NUT M10 DIN 934
16	600.616	SCREW M12x35 DIN 933 8.8	53	205.041	HUB ASSY
17	600.077	NUT M12 DIN 980	54	600.011	DUST COVER
18	250.697	REAR SECTION, RH	55	600.014	BEARING 30204
19	250.696	CENTRAL SECTION, RH	56	600.013	WHEEL HUB
20	250.695	FRONT SECTION, RH	57	600.016	SAFETY CAP
21	250.698	EXTENSION SECTION, RH (QRX14 only)	58	205.277	PIN
22	230.319	PIN	59	600.301	SPLIT PIN ø3x30 DIN 94
23	600.656	SPRING PIN ø12x70 DIN 1481	60	600.034	GREASE NIPPLE M8
24	200.199	BUSH	61	600.012	BEARING 30205
25	250.725	NYLON PLATE	62	600.015	LOCKING NUT M18x1,5
26	250.727	NYLON PLATE	63	250.702	REAR SECTION, LH
27	630.136	SCREW M8x25 DIN 7991A	64	250.701	CENTRAL SECTION, LH
28	610.185	WASHER ø9-21x2 UNI 6593	65	250.700	FRONT SECTION, LH
29	250.728	ARM EXTERNAL, RH	66	250.703	EXTENSION SECTION, LH (QRX14 only)
30	230.666	BUSH	67	630.586	PIN
31	250.730	ARM INTERNAL	68	630.375	FORK M16
32	250.729	ARM EXTERNAL, LH	69	230.729	NUT M22
33	230.716	SPRING	70	230.658	ROD
34	230.712	PIN	71	230.662	WASHER ø23-50x8
35	600.037	NUT M8 DIN 934	72	230.709	WASHER ø13-50x4
36	600.082	NUT M16 DIN 936	73	600.018	SPRING WASHER ø13 DIN 125A
37	630.571	KNOB	74	600.441	SCREW M12x25 DIN 933 8.8
38	260.148	WHEEL ARM SPECIAL, LH	75	230.667	WASHER ø25-90x10
39	600.124	GREASE NIPPLE M6	76	260.135	WHEEL ARM, RH
40	260.136	WHEEL ARM, LH	77	260.070	SHIM PLATE 1.5mm (0,059")
				260.073	SHIM PLATE 1mm (0,039")
			78	640.259	SCREW M8x30 DIN 7991A
			80	260.864	WASHER ø26-50x10

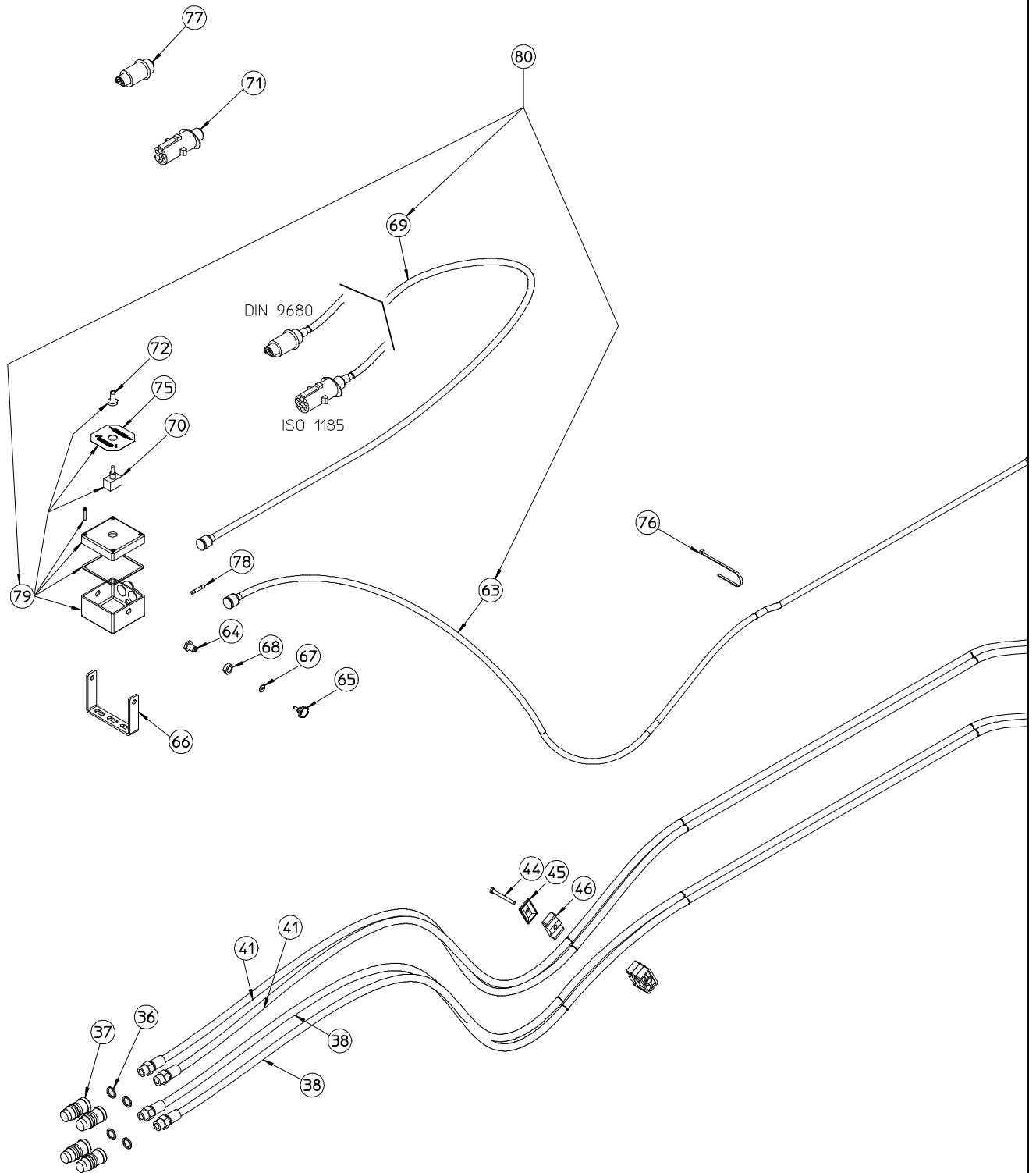

TABLE 920.403 HYDRAULIC SET					
Pos.	Part No.	Description	Pos.	Part No.	Description
1	250.709	EXTENSION CYL. ø50mm(2")-ø25mm(1")	39	640.125	HOSE 1/4"
2	600.031	WASHER ø17 UNI 6592	40	630.623	HOSE 1/4"
3	230.713	PIN	41	630.625	HOSE 1/4" (QRX12 only)
4	600.080	NUT M16 DIN 980		640.110	HOSE 1/4" (QRX14 only)
5	620.492	VALVE 1/4" 170 bar	42	610.901	SCREW M6x60 DIN 912 8.8
6	630.333	LOCK VALVE	43	610.035	HOSE COLLAR
7	630.331	NIPPLE 1/4"- 1/4" OREFICE 0.6mm	44	610.525	SCREW M8x60 DIN 931 8.8
8	630.334	FITTING MALE 1/4" FEMALE ø12	45	610.164	PLATE
9	600.883	NIPPLE 1/4"-3/8"	46	630.457	HOSE COLLAR ø16
10	632.362	FITTING MALE 1/4" FEMALE 1/4"	47	640.123	HOSE 1/4"
11	620.452	COPPER WASHER 3/8"	48	640.122	HOSE 1/4"
12	600.040	FITTING SCREW	49	631.360	SCREW M6x50 DIN 912 8.8
13	630.320	NIPPLE 1/4"- 1/4"		600.061	SCREW M8x16 DIN 933 8.8
14	630.376	COPPER WASHER 1/4"	50	600.229	SPRING WASHER ø8,4 DIN 125A
15	250.752	HYDRAULIC TUBE ø12	51	600.076	NUT M8 DIN 980
16	630.315	TURNING FITTING FD-OC	52	600.115	WASHER ø8,4 UNI 6592
17	640.127	SET OF GASKET	53	600.851	SCREW M8x35 DIN 933 8.8
18	230.383	ANGLING CYL. ø50mm(2")-ø20mm(0.8")	54	620.462	FITTING 3/8" MALE - 1/4" FEMALE
19	250.707	SPACER	55	632.246	FITTING BANJO 1/4" - MALE 1/4"
20	250.705	PIN	56	260.931	VALVE SUPPORT
21	630.325	SET OF GASKET	57	640.116	ELECTROVALVE, FLOW SELECTOR
22	230.377	BUSH	58	600.880	FITTING T 1/4" MALE-FEMALE-MALE
23	230.669	PIN	59	632.667	FITTING 90° 1/4" MALE - FEMALE 1/4"
24	630.332	FITTING BANJO 1/4" - FEMALE 1/4"	63*	640.170	VALVE CABLE
25	630.532	FITTING BANJO 1/4" WITH TUBE	64	230.615	PIN
26	600.820	FITTING 1/4"	65	630.486	KNOB
27	250.708	FOLDUP CYL. ø80mm(3.15")-ø30(1.18")	66	250.751	CONTROL BOX SUPPORT
28	600.336	WASHER ø25	67	630.490	WASHER ø5,3-15x1,6 UNI 6593
29	600.038	SPLIT PIN D6x35 DIN 94 3.6	68	600.132	NUT M12 DIN 936
30	230.368	PIN	69	640.209	CABLE 7-PIN ISO1185 (USA)
31	600.270	NIPPLE 3/8"- 3/8"		640.210	CABLE 3-PIN DIN9680
32	200.192	NIPPLE 3/8"- 3/8" OREFICE 0,8	70	640.227	SWITCH
33	610.002	VALVE	71	630.688	ELECTRICAL PLUG 7-PIN ISO1185 (USA)
34	610.340	SET OF GASKET	72	630.517	SWITCH PROTECTION
35	600.823	FITTING M-M-M 1/4"	75	001.790	LABEL
36	630.048	COPPER WASHER 1/2"	75	001.790	LABEL
37	600.273	RAPID COUPLING 1/2"	76	620.039	STRIP
38	630.626	HOSE 1/4" (QRX12 only)	77	634.804	ELECTRICAL PLUG 3-PIN DIN9680
	640.109	HOSE 1/4" (QRX14 only)	78	640.199	FUSE 5A D.5mm L.20mm
			79	640.211	CONTROL BOX
			80	250.743	ELECTRICAL SYSTEM COMPL. ISO1185 (USA)
				250.900	ELECTRICAL SYSTEM COMPLETE DIN9680
			83	610.930	BANJO MALE 3/8"
			84	610.469	FITTING MALE 3/8" TUBE ø12
			85	260.565	HYDRAULIC TUBE ø12
			86	600.271	FITTING MALE-FEMALE 3/8"
			87	600.799	LOCK VALVE 3/8"

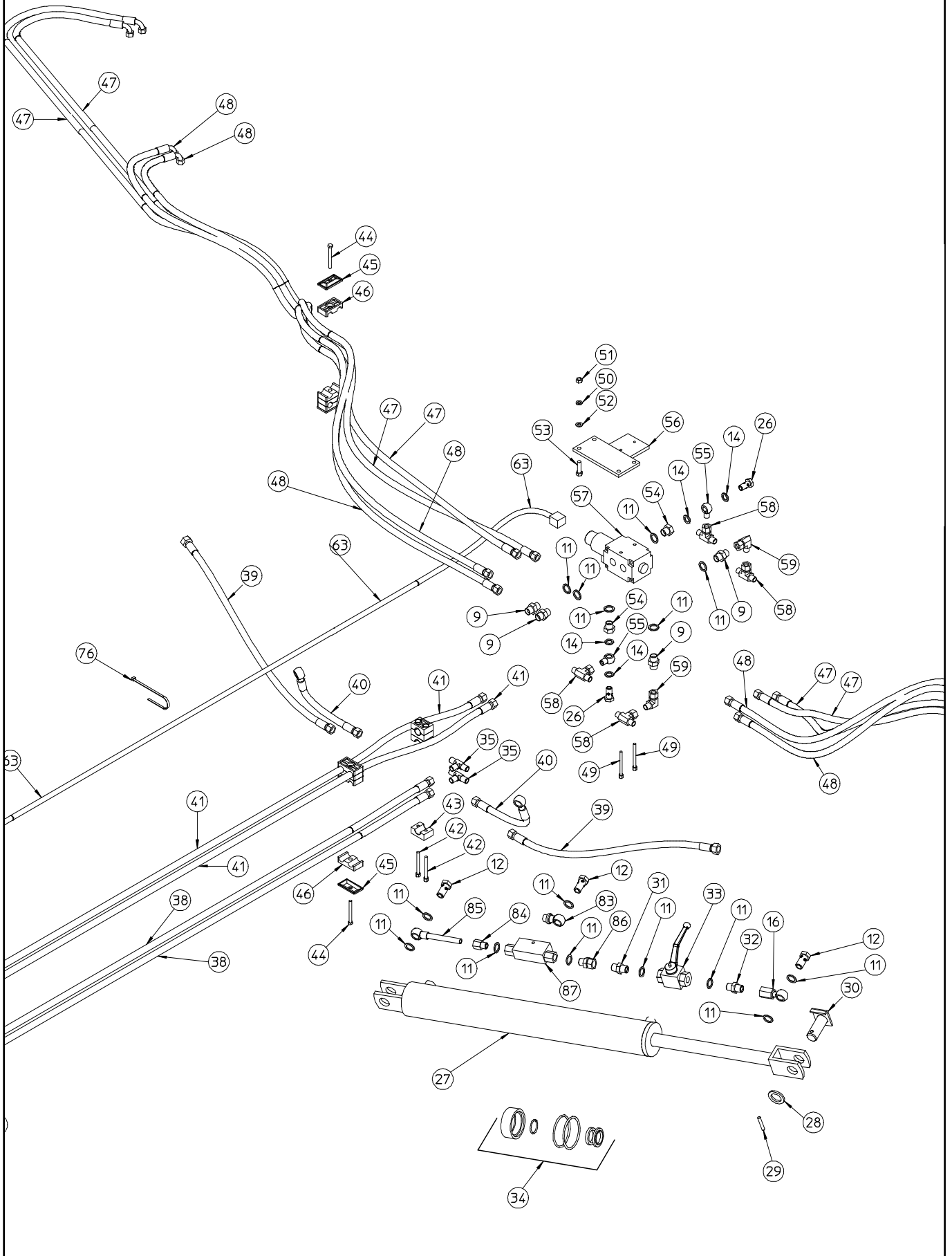

TABLE 920.403 HYDRAULIC SET

Pos.	Part No.	Description	Pos.	Part No.	Description
1	250.709	EXTENSION CYL. ø50mm(2")-ø25mm(1")	39	640.125	HOSE 1/4"
2	600.031	WASHER ø17 UNI 6592	40	630.623	HOSE 1/4"
3	230.713	PIN	41	630.625	HOSE 1/4" (QRX12 only)
4	600.080	NUT M16 DIN 980	41	640.110	HOSE 1/4" (QRX14 only)
5	620.492	VALVE 1/4" 170 bar	42	610.901	SCREW M6x60 DIN 912 8.8
6	630.333	LOCK VALVE	43	610.035	HOSE COLLAR
7	630.331	NIPPLE 1/4"- 1/4" OREFICE 0.6mm	44	610.525	SCREW M8x60 DIN 931 8.8
8	630.334	FITTING MALE 1/4" FEMALE ø12	45	610.164	PLATE
9	600.883	NIPPLE 1/4"-3/8"	46	630.457	HOSE COLLAR ø16
10	632.362	FITTING MALE 1/4" FEMALE 1/4"	47	640.123	HOSE 1/4"
11	620.452	COPPER WASHER 3/8"	48	640.122	HOSE 1/4"
12	600.040	FITTING SCREW	49	631.360	SCREW M6x50 DIN 912 8.8
13	630.320	NIPPLE 1/4"- 1/4"	49	600.061	SCREW M8x16 DIN 933 8.8
14	630.376	COPPER WASHER 1/4"	50	600.229	SPRING WASHER ø8,4 DIN 125A
15	250.752	HYDRAULIC TUBE ø12	51	600.076	NUT M8 DIN 980
16	630.315	TURNING FITTING FD-OC	52	600.115	WASHER ø8,4 UNI 6592
17	640.127	SET OF GASKET	53	600.851	SCREW M8x35 DIN 933 8.8
18	230.383	ANGLING CYL. ø50mm(2")-ø20mm(0.8")	54	620.462	FITTING 3/8" MALE - 1/4" FEMALE
19	250.707	SPACER	55	632.246	FITTING BANJO 1/4" - MALE 1/4"
20	250.705	PIN	56	260.931	VALVE SUPPORT
21	630.325	SET OF GASKET	57	640.116	ELECTROVALVE, FLOW SELECTOR
22	230.377	BUSH	58	600.880	FITTING T 1/4" MALE-FEMALE-MALE
23	230.669	PIN	59	632.667	FITTING 90° 1/4" MALE - FEMALE 1/4"
24	630.332	FITTING BANJO 1/4" - FEMALE 1/4"	63*	640.170	VALVE CABLE
25	630.532	FITTING BANJO 1/4" WITH TUBE	64	230.615	PIN
26	600.820	FITTING 1/4"	65	630.486	KNOB
27	250.708	FOLDUP CYL. ø80mm(3.15")-ø30(1.18")	66	250.751	CONTROL BOX SUPPORT
28	600.336	WASHER ø25	67	630.490	WASHER ø5,3-15x1,6 UNI 6593
29	600.038	SPLIT PIN D6x35 DIN 94 3.6	68	600.132	NUT M12 DIN 936
30	230.368	PIN	69	640.209	CABLE 7-PIN ISO1185 (USA)
31	600.270	NIPPLE 3/8"- 3/8"	69	640.210	CABLE 3-PIN DIN9680
32	200.192	NIPPLE 3/8"- 3/8" OREFICE 0,8	70	640.227	SWITCH
33	610.002	VALVE	71	630.688	ELECTRICAL PLUG 7-PIN ISO1185 (USA)
34	610.340	SET OF GASKET	72	630.517	SWITCH PROTECTION
35	600.823	FITTING M-M-M 1/4"	75	001.790	LABEL
36	630.048	COPPER WASHER 1/2"	75	001.790	LABEL
37	600.273	RAPID COUPLING 1/2"	76	620.039	STRIP
38	630.626	HOSE 1/4" (QRX12 only)	77	634.804	ELECTRICAL PLUG 3-PIN DIN9680
	640.109	HOSE 1/4" (QRX14 only)	78	640.199	FUSE 5A D.5mm L.20mm
			79	640.211	CONTROL BOX
			80	250.743	ELECTRICAL SYSTEM COMPL. ISO1185 (USA)
			80	250.900	ELECTRICAL SYSTEM COMPLETE DIN9680
			83	610.930	BANJIO MALE 3/8"
			84	610.469	FITTING MALE 3/8" TUBE ø12
			85	260.565	HYDRAULIC TUBE ø12
			86	600.271	FITTING MALE-FEMALE 3/8"
			87	600.799	LOCK VALVE 3/8"

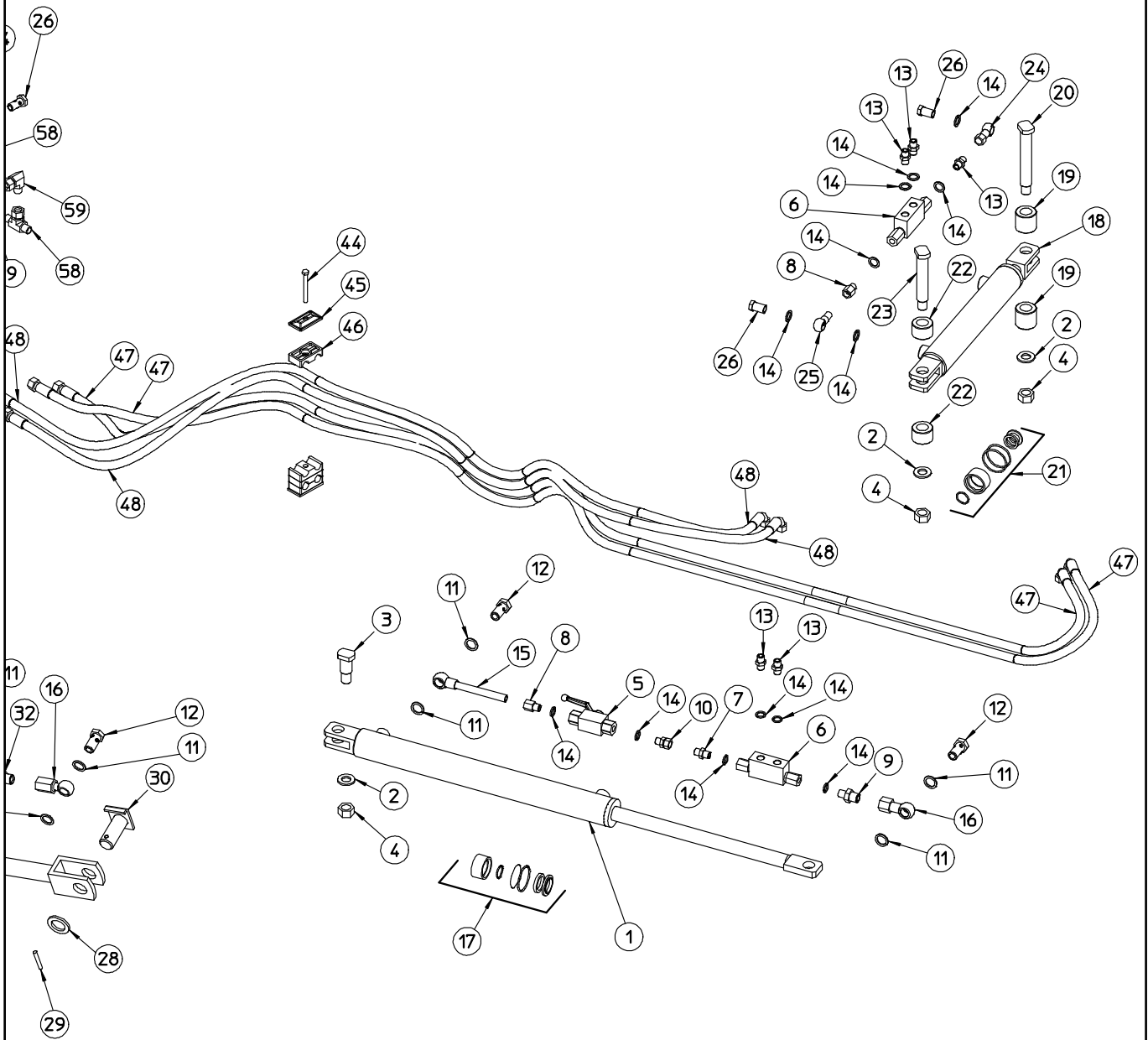
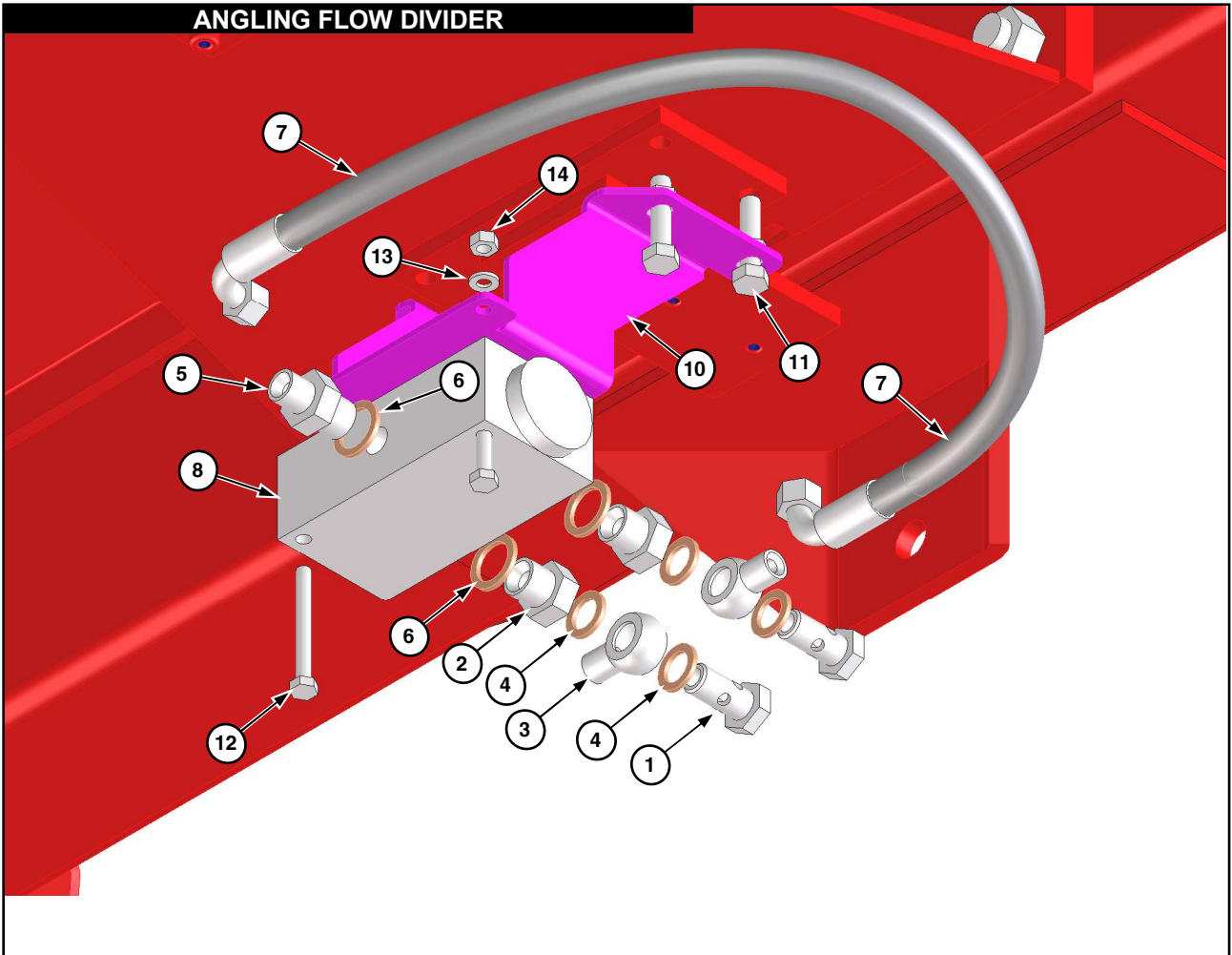

TABLE 920.403 HYDRAULIC SET

Pos.	Part No.	Description	Pos.	Part No.	Description
1	250.709	EXTENSION CYL. ø50mm(2")-ø25mm(1")	39	640.125	HOSE 1/4"
2	600.031	WASHER ø17 UNI 6592	40	630.623	HOSE 1/4"
3	230.713	PIN	41	630.625	HOSE 1/4" (QRX12 only)
4	600.080	NUT M16 DIN 980		640.110	HOSE 1/4" (QRX14 only)
5	620.492	VALVE 1/4" 170 bar	42	610.901	SCREW M6x60 DIN 912 8.8
6	630.333	LOCK VALVE	43	610.035	HOSE COLLAR
7	630.331	NIPPLE 1/4"- 1/4" OREFICE 0.6mm	44	610.525	SCREW M8x60 DIN 931 8.8
8	630.334	FITTING MALE 1/4" FEMALE ø12	45	610.164	PLATE
9	600.883	NIPPLE 1/4"-3/8"	46	630.457	HOSE COLLAR ø16
10	632.362	FITTING MALE 1/4" FEMALE 1/4"	47	640.123	HOSE 1/4"
11	620.452	COPPER WASHER 3/8"	48	640.122	HOSE 1/4"
12	600.040	FITTING SCREW	49	631.360	SCREW M6x50 DIN 912 8.8
13	630.320	NIPPLE 1/4"- 1/4"		600.061	SCREW M8x16 DIN 933 8.8
14	630.376	COPPER WASHER 1/4"	50	600.229	SPRING WASHER ø8,4 DIN 125A
15	250.752	HYDRAULIC TUBE ø12	51	600.076	NUT M8 DIN 980
16	630.315	TURNING FITTING FD-OC	52	600.115	WASHER ø8,4 UNI 6592
17	640.127	SET OF GASKET	53	600.851	SCREW M8x35 DIN 933 8.8
18	230.383	ANGLING CYL. ø50mm(2")-ø20mm(0.8")	54	620.462	FITTING 3/8" MALE - 1/4" FEMALE
19	250.707	SPACER	55	632.246	FITTING BANJO 1/4" - MALE 1/4"
20	250.705	PIN	56	260.931	VALVE SUPPORT
21	630.325	SET OF GASKET	57	640.116	ELECTROVALVE, FLOW SELECTOR
22	230.377	BUSH	58	600.880	FITTING T 1/4" MALE-FEMALE-MALE
23	230.669	PIN	59	632.667	FITTING 90° 1/4" MALE - FEMALE 1/4"
24	630.332	FITTING BANJO 1/4" - FEMALE 1/4"	63*	640.170	VALVE CABLE
25	630.532	FITTING BANJO 1/4" WITH TUBE	64	230.615	PIN
26	600.820	FITTING 1/4"	65	630.486	KNOB
27	250.708	FOLDUP CYL. ø80mm(3.15")-ø30(1.18")	66	250.751	CONTROL BOX SUPPORT
28	600.336	WASHER ø25	67	630.490	WASHER ø5,3-15x1,6 UNI 6593
29	600.038	SPLIT PIN D6x35 DIN 94 3.6	68	600.132	NUT M12 DIN 936
30	230.368	PIN	69	640.209	CABLE 7-PIN ISO1185 (USA)
31	600.270	NIPPLE 3/8"- 3/8"		640.210	CABLE 3-PIN DIN9680
32	200.192	NIPPLE 3/8"- 3/8" OREFICE 0,8	70	640.227	SWITCH
33	610.002	VALVE	71	630.688	ELECTRICAL PLUG 7-PIN ISO1185 (USA)
34	610.340	SET OF GASKET	72	630.517	SWITCH PROTECTION
35	600.823	FITTING M-M-M 1/4"	75	001.790	LABEL
36	630.048	COPPER WASHER 1/2"	75	001.790	LABEL
37	600.273	RAPID COUPLING 1/2"	76	620.039	STRIP
38	630.626	HOSE 1/4" (QRX12 only)	77	634.804	ELECTRICAL PLUG 3-PIN DIN9680
	640.109	HOSE 1/4" (QRX14 only)	78	640.199	FUSE 5A D.5mm L.20mm
			79	640.211	CONTROL BOX
			80	250.743	ELECTRICAL SYSTEM COMPL. ISO1185 (USA)
				250.900	ELECTRICAL SYSTEM COMPLETE DIN9680
			83	610.930	BANJO MALE 3/8"
			84	610.469	FITTING MALE 3/8" TUBE ø12
			85	260.565	HYDRAULIC TUBE ø12
			86	600.271	FITTING MALE-FEMALE 3/8"
			87	600.799	LOCK VALVE 3/8"

ANGLING FLOW DIVIDER



ANGLING FLOW DIVIDER				
Pos.	PART. NO	Qty	DESCRIPTION	NOTE
1	600.820	2	FITTING SCREW 1/4"	
2	620.462	2	FITTING NIPPLE 3/8"M - 1/4"F	
3	632.246	2	BANJO 1/4"	
4	630.376	4	WASHER 1/4" BONDED	
5	600.883	1	NIPPLE 3/8" GAS - 1/4" GAS	
6	620.452	3	WASHER 3/8" BONDED	
7	640.275	1	HOSE F90° 1/4" - F90° 1/4"	
8	640.274	1	FLOW DIVIDER	
10	260.134	1	VALVE SUPPORT	
11	600.851	4	SCREW M8x35	
12	631.393	2	SCREW M6x55	
13	600.514	2	WASHER M6	
14	600.472	2	NUT M6	

REAR CENTER WHEELS KIT 260.698

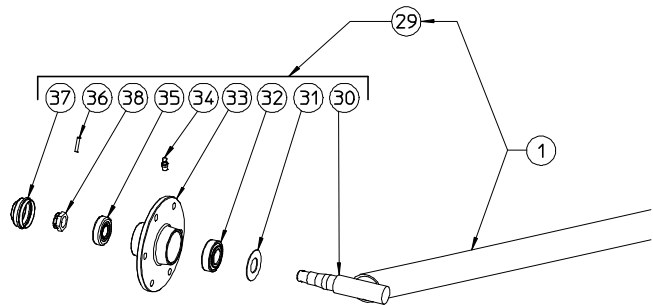
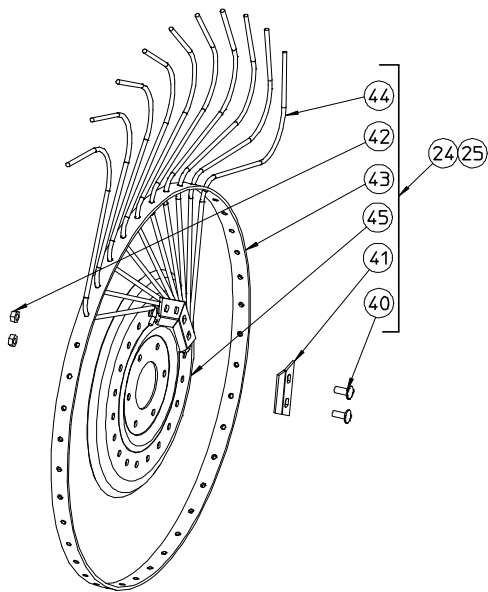
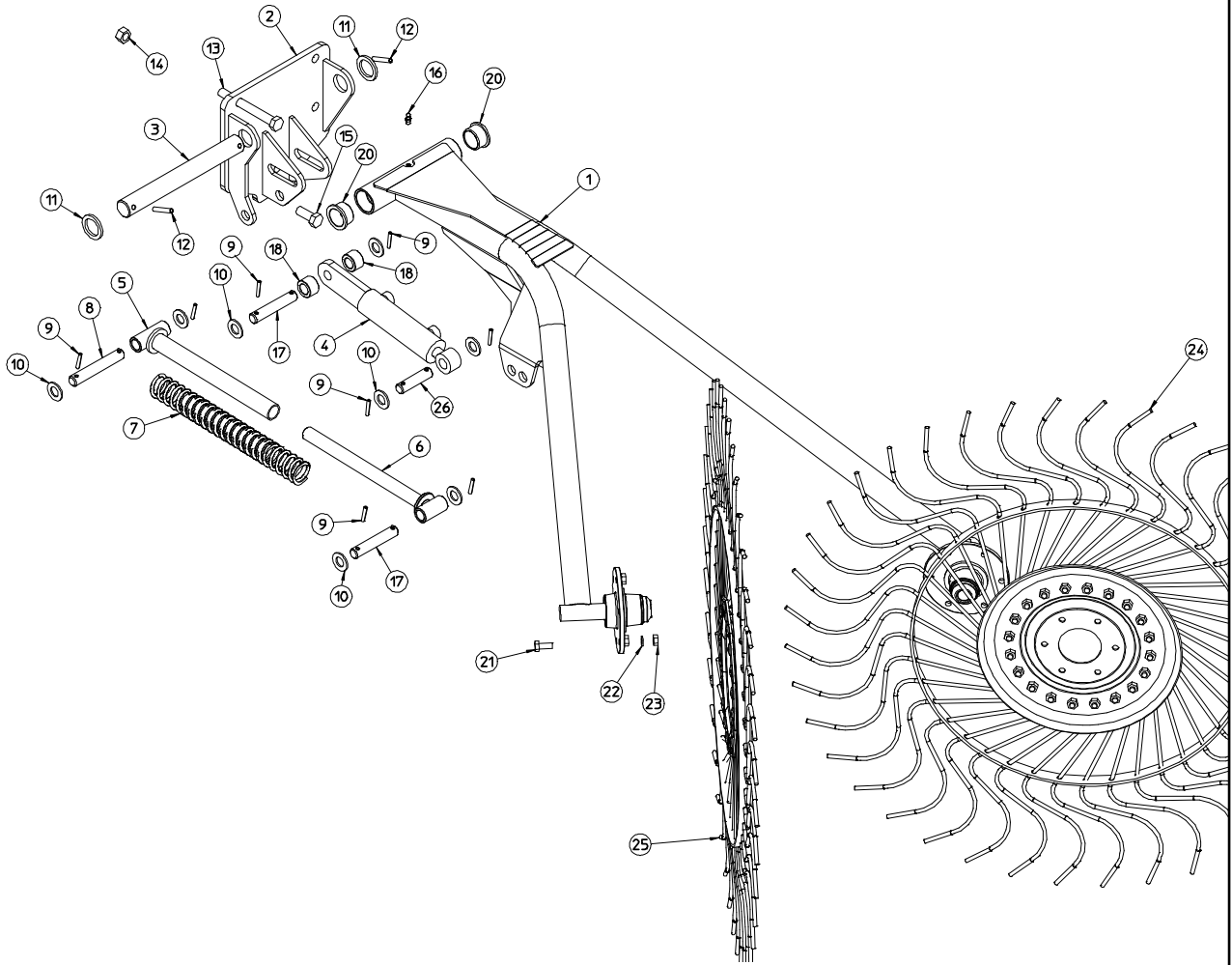

REAR CENTER WHEEL KIT 260.698				
Pos.	PART. NO	Qty	DESCRIPTION	NOTE
1	260.158	1	ARM	
2	260.160	1	SUPPORT	
3	260.159	1	PIN	
4	230.375	1	CYLINDER	
5	260.161	1	TIE ROD TUBE	
6	260.162	1	TIE ROD	
7	250.244	1	SPRING	
8	260.163	1	PIN	
9	600.538	8	SPING PIN ø6x35 DIN 1481	
10	600.632	8	WASHER ø21 DIN 125A	
11	200.028	2	WASHER ø35	
12	600.027	2	SPING PIN ø8x50 DIN 1481	
13	600.780	4	SCREW M16x160 DIN 931	
14	600.080	5	NUT M16 DIN 980	
15	600.035	1	SCREW M16x40 DIN 933	
16	600.124	1	GREASE NIPPLE M6	
17	230.378	2	PIN	
18	230.377	2	SPACER	
20	200.029	2	BUSH	
21	600.006	12	SCREW M10x25 DIN 603	
22	600.024	12	SPRING WASHER D 10,5 (DIN 127B)	
23	600.010	12	SCREW M10 x 25 DIN 933	
24	250.453	1	WHEEL ASSY L.H. 44" (TINE DIA 0,276" 7mm)	Mounted on RH side
25	250.452	1	WHEEL ASSY R.H. 44" (TINE DIA 0,276" 7mm)	Mounted on LH side
26	260.164	1	PIN	
29	205.041	1	HUB ASSY	
30	205.277	1	PIN	
31	600.011	1	DUST COVER	
32	600.012	1	BEARING 30205	
33	600.013	1	WHEEL HUB	
34	600.034	1	GREASE NIPPLE M8	
35	600.014	1	BEARING 30204	
36	600.301	1	SPLIT PIN ø3x30 DIN 94	
37	600.016	1	SAFETY CAP	
38	600.015	1	LOCKING NUT M18x1,5	
40	600.005	20	SCREW M10x25 DIN 603	
41	200.012	10	TINE CLAMP	
42	600.029	20	NUT M10 DIN 980	
43	230.352	1	RIM	
44	230.349	40	TINE DIA 0,276" (7mm)	
45	200.010	1	FLANGE	

REAR CENTER WHEELS KIT 260.698 HYDRAULIC SET

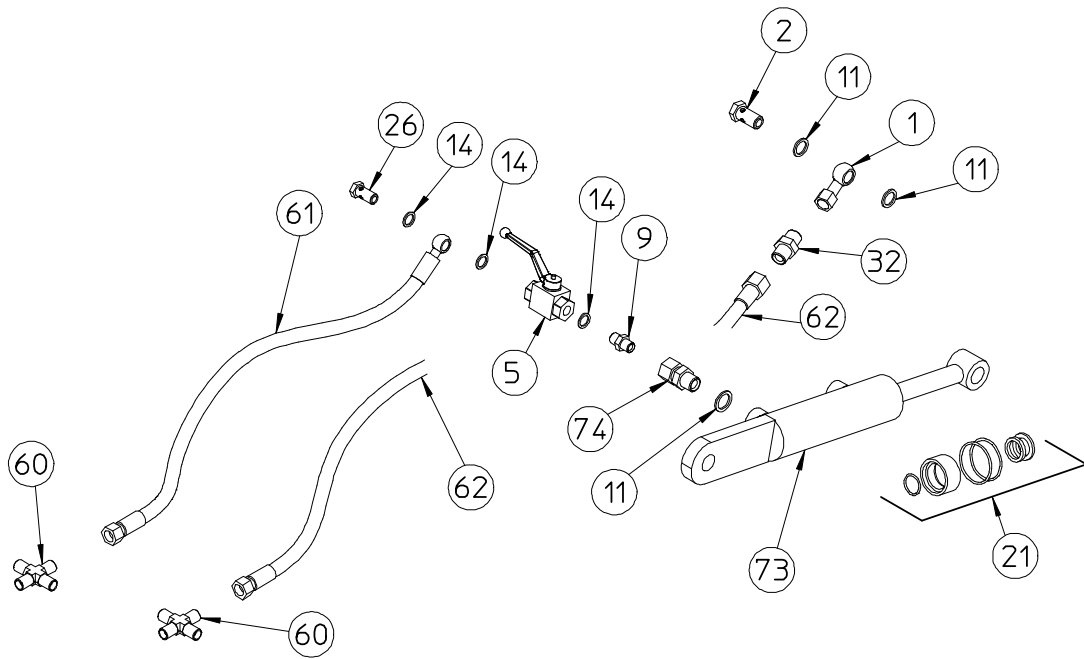

HYDRAULIC SET

Pos.	PART.NO	Qty	DESCRIPTION	NOTE
1	630.315	1	BANJO 3/8"	
2	600.040	1	FITTING 3/8"	
5	620.492	1	VALVE 1/4" 170 bar	
9	600.883	1	NIPPLE 1/4"-3/8"	
11	620.452	3	COPPER WASHER 3/8"	
14	630.376	3	COPPER WASHER 1/4"	
21	630.325	1	SET OF GASKET	
26	600.820	1	FITTING 1/4"	
32	200.192	1	NIPPLE 3/8"- 3/8" OREFICE 0,8	
60	620.978	2	FITTING CROSS 1/4" MALE	
61	640.285	1	HOSE 1/4" FO L. 640mm	
62	640.284	1	HOSE 1/4" FF L. 730mm	
73	230.375	1	CYLINDER	
74	600.271	1	FITTING 3/8" MALE-3/8" FEMALE	

CONVERSION KIT QRX/12 INTO QRX/14
Part No. 250.785 with 55" RAKE WHEELS
Part No. 250.763 with 60" RAKE WHEELS

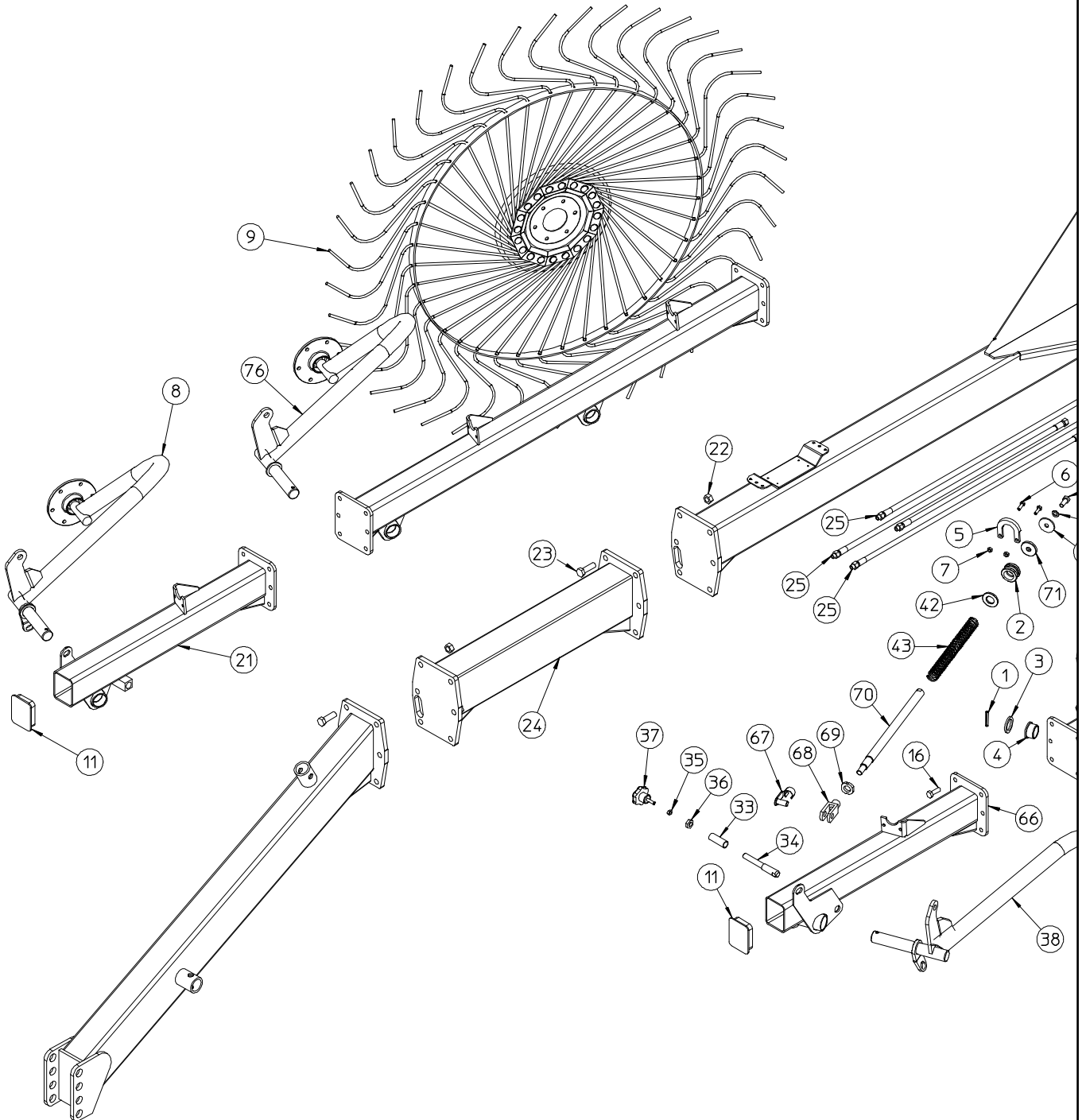

CONVERSION KIT QRX/12 INTO QRX/14 (250.785 with 55" Rake Wheels - 250.763 with 60" Rake Wheels)				
Pos.	Part No.	Qty	Description	NOTE
1	600.027	2	SPRING PIN ø8x50	
2	230.659	2	BUSH	
3	200.028	2	WASHER ø35,5-50x5	
4	200.029	4	BUSH	
5	230.664	2	SUPPORT	
6	600.702	4	SCREW M8x25 DIN 933 8.8	
7	600.076	4	NUT M8 DIN 980	
8	260.147	1	WHEEL ARM SPECIAL, RH	
9	210.180	1	WHEEL ASSY 55", RH	
	230.279	1	WHEEL ASSY 60", RH	OPTIONAL
11	640.108	2	PLUG ()	
16	600.616	12	SCREW M12x35 DIN 933 8.8	
17	600.077	12	NUT M12 DIN 980	
21	250.698	1	EXTENSION SECTION, RH	
22	600.080	6	NUT M16 DIN 980	
23	600.176	6	SCREW M16x50 DIN 931 8.8	
24	250.718	1	DRAWBAR ()	
25	640.124	4	HOSE 1/4" LG. 900mm	
33	230.716	2	SPRING	
34	230.712	2	PIN	
35	600.037	2	NUT M8 DIN 934	
36	600.082	2	NUT M16 DIN 936	
37	630.571	2	KNOB	
38	260.148	1	WHEEL ARM SPECIAL, LH	
39	600.968	2	GREASE NIPPLE M6x45"	
40	260.136	-	WHEEL ARM, LH	
41	210.181	1	WHEEL ASSY 55", LH	
	230.280	1	WHEEL ASSY 60", LH	OPTIONAL
42	230.661	2	WASHER ø26-55x5	
43	230.965	2	SPRING ø4mm	
44	200.010	2	FLANGE, WHEEL 55"	
	230.338	2	FLANGE, WHEEL 60"	OPTIONAL
45	200.009	2	RIM, WHEEL 55"	
	230.326	2	RIM, WHEEL 60"	OPTIONAL
46	200.012	20	TINE CLAMP	
47	210.621	80	TINE ø0,276" (7mm), WHEEL 55"	
	230.327	80	TINE ø0,295" (7,5mm), WHEEL 60" ()	OPTIONAL
48	600.005	40	SCREW M10x25 DIN 603	
49	600.029	40	NUT M10 DIN 980	
50	600.006	12	SCREW M10x25 DIN 933 8.8	
51	600.024	12	SPRING WASHER ø10,5 DIN 125A	
52	600.010	12	NUT M10 DIN 934	
53	205.041	2	HUB ASSY	
54	600.011	2	DUST COVER	
55	600.014	2	BEARING 30204	
56	600.013	2	WHEEL HUB	
57	600.016	2	SAFETY CAP	
58	205.277	2	PIN	
59	600.301	2	SPLIT PIN ø3x30 DIN 94	
60	600.034	2	GREASE NIPPLE M8	
61	600.012	2	BEARING 30205	
62	600.015	2	LOCKING NUT M18x1,5	
66	250.703	1	EXTENSION SECTION, LH	
67	630.586	2	PIN	
68	630.375	2	FORK M16	
69	230.729	2	NUT M22	
70	230.658	2	ROD	
71	230.662	2	WASHER ø23-50x8	
72	230.709	2	WASHER ø13-50x4	
73	600.018	2	SPRING WASHER ø13 DIN 125A	
74	600.441	2	SCREW M12x25 DIN 933 8.8	
76	260.135	-	WHEEL ARM, RH	

CONVERSION KIT QRX/12 INTO QRX/14 (250.785 with 55" Rake Wheels - 250.763 with 60" Rake Wheels)				
Pos.	Part No.	Qty	Description	NOTE
1	600.027	2	SPRING PIN ø8x50	
2	230.659	2	BUSH	
3	200.028	2	WASHER ø35,5-50x5	
4	200.029	4	BUSH	
5	230.664	2	SUPPORT	
6	600.702	4	SCREW M8x25 DIN 933 8.8	
7	600.076	4	NUT M8 DIN 980	
8	260.147	1	WHEEL ARM SPECIAL, RH	
9	210.180	1	WHEEL ASSY 55", RH	
	230.279	1	WHEEL ASSY 60", RH	OPTIONAL
11	640.108	2	PLUG ()	
16	600.616	12	SCREW M12x35 DIN 933 8.8	
17	600.077	12	NUT M12 DIN 980	
21	250.698	1	EXTENSION SECTION, RH	
22	600.080	6	NUT M16 DIN 980	
23	600.176	6	SCREW M16x50 DIN 931 8.8	
24	250.718	1	DRAWBAR ()	
25	640.124	4	HOSE 1/4" LG. 900mm	
33	230.716	2	SPRING	
34	230.712	2	PIN	
35	600.037	2	NUT M8 DIN 934	
36	600.082	2	NUT M16 DIN 936	
37	630.571	2	KNOB	
38	260.148	1	WHEEL ARM SPECIAL, LH	
39	600.968	2	GREASE NIPPLE M6x45"	
40	260.136	-	WHEEL ARM, LH	
41	210.181	1	WHEEL ASSY 55", LH	
	230.280	1	WHEEL ASSY 60", LH	OPTIONAL
42	230.661	2	WASHER ø26-55x5	
43	230.965	2	SPRING ø4mm	
44	200.010	2	FLANGE, WHEEL 55"	
	230.338	2	FLANGE, WHEEL 60"	OPTIONAL
45	200.009	2	RIM, WHEEL 55"	
	230.326	2	RIM, WHEEL 60"	OPTIONAL
46	200.012	20	TINE CLAMP	
47	210.621	80	TINE ø0,276" (7mm), WHEEL 55"	
	230.327	80	TINE ø0,295" (7,5mm), WHEEL 60" ()	OPTIONAL
48	600.005	40	SCREW M10x25 DIN 603	
49	600.029	40	NUT M10 DIN 980	
50	600.006	12	SCREW M10x25 DIN 933 8.8	
51	600.024	12	SPRING WASHER ø10,5 DIN 125A	
52	600.010	12	NUT M10 DIN 934	
53	205.041	2	HUB ASSY	
54	600.011	2	DUST COVER	
55	600.014	2	BEARING 30204	
56	600.013	2	WHEEL HUB	
57	600.016	2	SAFETY CAP	
58	205.277	2	PIN	
59	600.301	2	SPLIT PIN ø3x30 DIN 94	
60	600.034	2	GREASE NIPPLE M8	
61	600.012	2	BEARING 30205	
62	600.015	2	LOCKING NUT M18x1,5	
66	250.703	1	EXTENSION SECTION, LH	
67	630.586	2	PIN	
68	630.375	2	FORK M16	
69	230.729	2	NUT M22	
70	230.658	2	ROD	
71	230.662	2	WASHER ø23-50x8	
72	230.709	2	WASHER ø13-50x4	
73	600.018	2	SPRING WASHER ø13 DIN 125A	
74	600.441	2	SCREW M12x25 DIN 933 8.8	
76	260.135	-	WHEEL ARM, RH	

SAFETY CHAIN

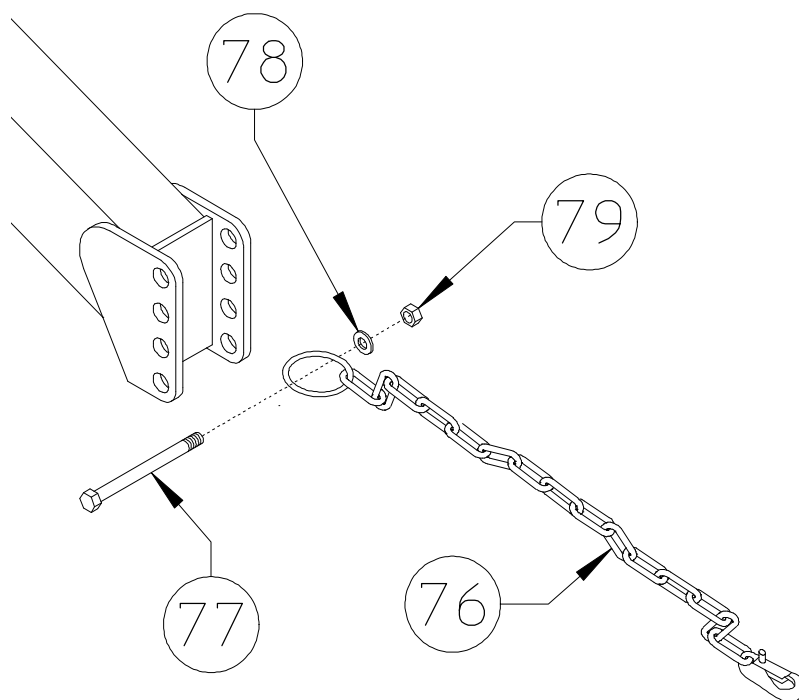

ITEM	Q.ty	PART NO	DESCRIPTION
76	1	220.500	CHAINE
77	1	620.019	SCREW M22x150 DIN 931
78	1	600.214	SPRING WASHER $\varnothing 23$
79	1	600.200	NUT M22 DIN 934

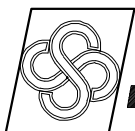

AGRICULTURAL MACHINERY
sitrex® SpA

Zona Industriale-Viale Grecia, 8
06018 TRESTINA-(Perugia)-ITALY
Tel. +39.075.8540021-Telefax +39.075.8540523
e-mail: sitrex@sitrex.it www.sitrex.com

